

# RKP-II

## RADIAL PISTON PUMP

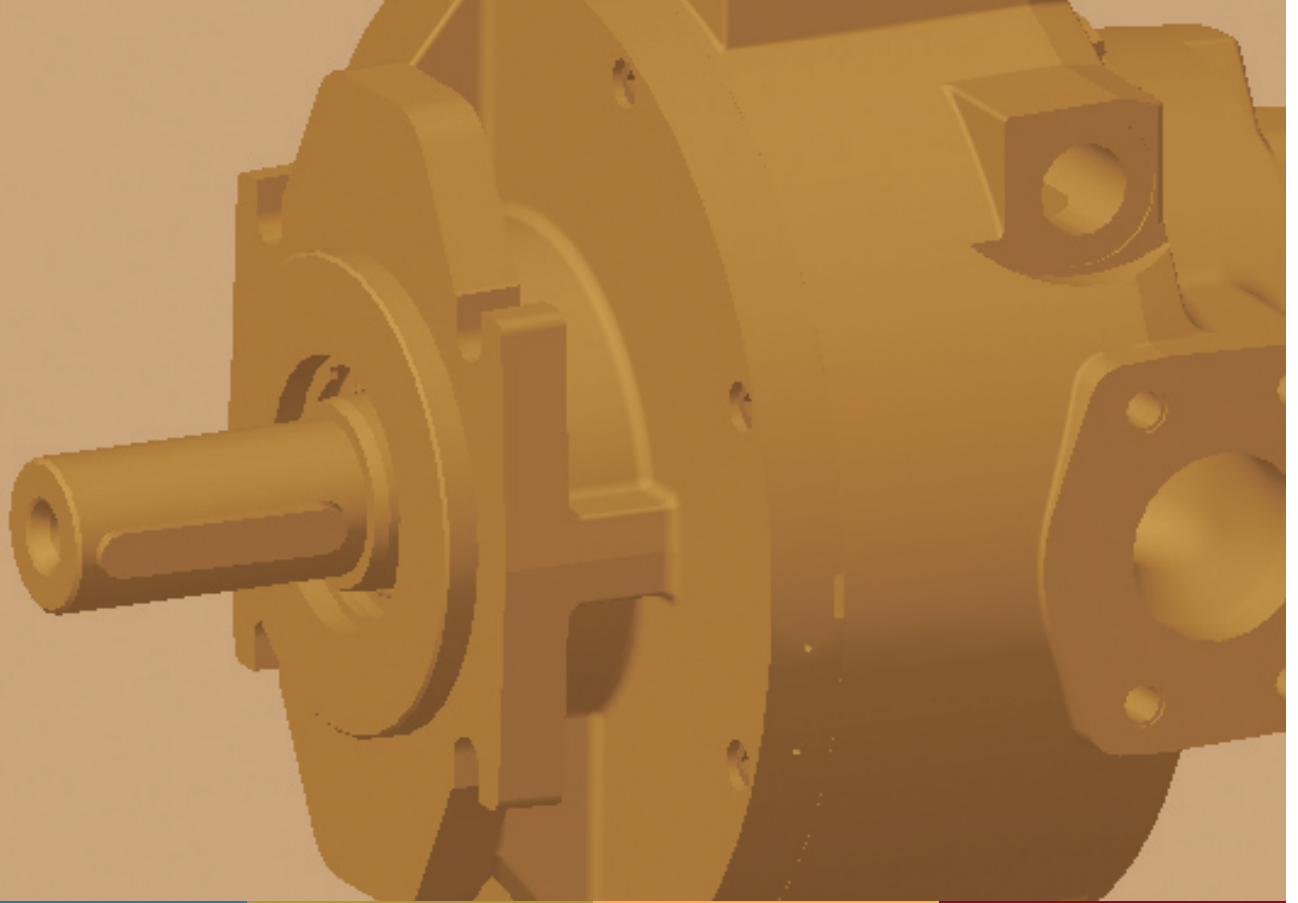

MOOG RKP PUMPS OFFER LOW NOISE, UNSURPASSED RELIABILITY, LONG LIFE, AND A WIDE VARIETY OF CONTROL OPTIONS FOR DEMANDING APPLICATIONS

# RADIAL PISTON PUMPS RKP-II

## CROSS SECTION RKP-II

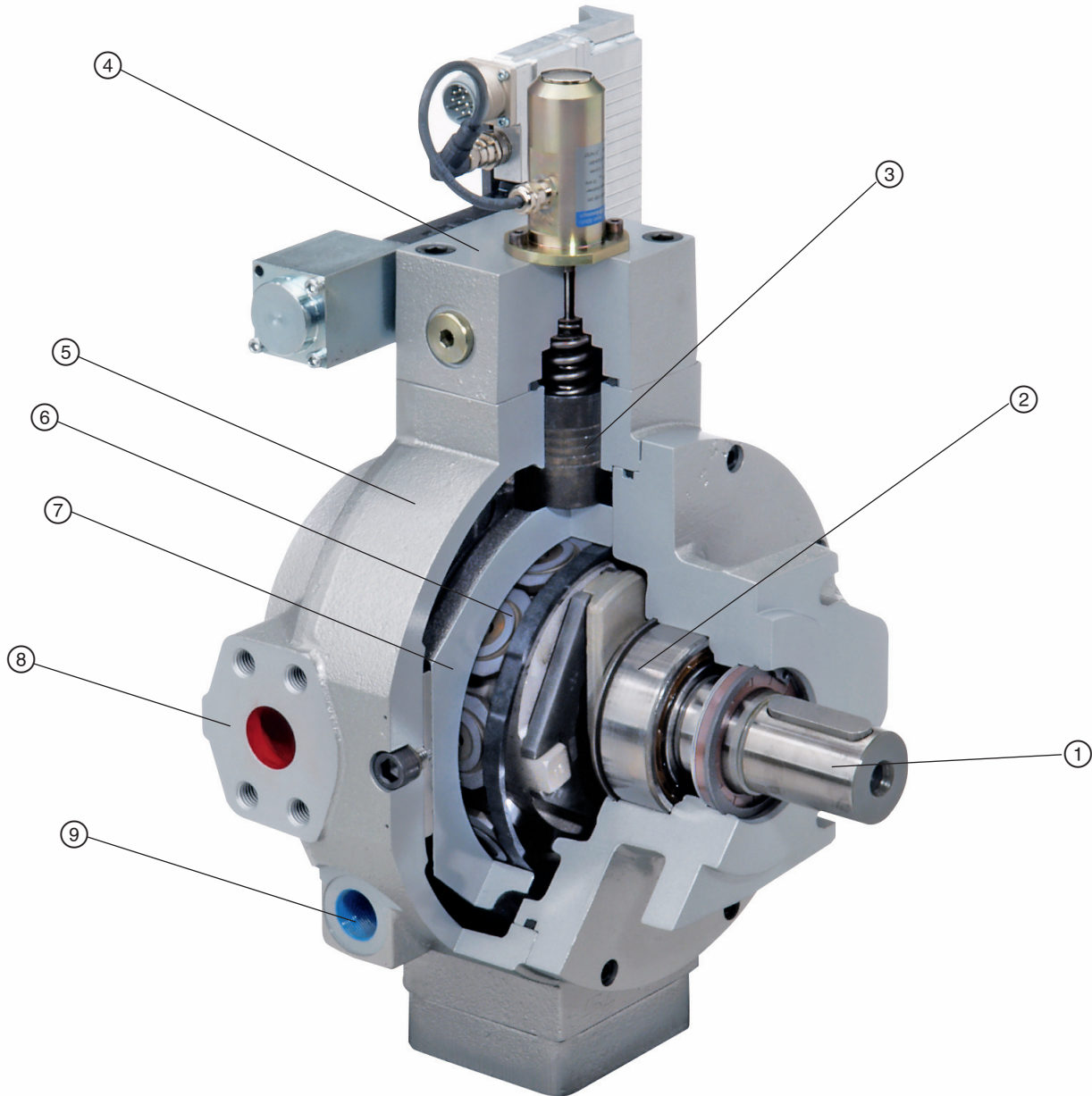

- ① Drive shaft
- ② Roller bearing
- ③ Control piston
- ④ Compensator
- ⑤ Housing
- ⑥ Slipper pads
- ⑦ Sliding stroke ring
- ⑧ SAE connection
- ⑨ Drain port

# RADIAL PISTON PUMPS RKP-II

## TABLE OF CONTENTS

---

### TABLE OF CONTENTS

<b>Contents</b>	<b>Page</b>
Cross section	2
Table of contents	3
Introduction	4
New design	5
Technical data	6
Performance curves	7
Compensator options	10
Multiple arrangements	11
Model code	15
Technical information	18
Appendix A – Compensator options	19
Appendix B – Technical drawings	30
Conversion table	58
Worldwide Support and further Information	59

### IMPORTANT NOTE

This catalog is intended for users with some technical knowledge. To ensure that all necessary characteristics for function and safety are covered, the user must check the suitability of the products described herein. The products are subject to change without notice. In case of doubt, please contact Moog.

Moog is a registered trademark of Moog Inc. and its subsidiaries. Unless expressly indicated, all trademarks indicated herein are the property of Moog Inc. and its subsidiaries. For a complete disclaimer, please go to [www.moog.com/literature/disclaimers](http://www.moog.com/literature/disclaimers).

© Moog Inc. 2007. All rights reserved.  
All changes are reserved.

For the most up to date information please visit our website [www.moog.com/industrial/RKPHighPerformance](http://www.moog.com/industrial/RKPHighPerformance).

# RADIAL PISTON PUMPS RKP-II

## INTRODUCTION

---

### GENERAL INFORMATION

#### Outstanding motion control solutions

For over 50 years, we have been a leader in motion control technology, specialising in the manufacture and application of high performance products. Today, we incorporate the latest motion control technology into our products and offer innovative ideas that can help our customers achieve new levels of machine performance.

#### Proven pump technology

The Radial Piston Pump product line (also known as RKP), is a range of high performance variable displacement pumps intended for use in industrial applications. Based on a proven concept, the RKP's robust and contamination resistant design results in long life and a high degree of reliability.

Its rapid response time and high volumetric efficiency have led to it being the first choice for many machines with demanding flow and pressure control needs.

We produce a wide range of radial piston pumps of different sizes, single and multiple arrangements, with various forms of control (mechanical, hydro-mechanical, electro-hydraulic, digital and analogue) in order to provide maximum flexibility to machine builders.

#### Applications

Thanks to the flexible, high performance design, the new RKP-II is the ideal solution for all types of industrial applications. The RKP is already used in machines for injection molding, die casting, forming equipment such as presses and rolls, as well as in general hydraulic applications. In the field of plastic and metal processing, the RKP is used on equipment to produce plastic and metal parts, for the packaging and automotive industries. The RKP is also used in test equipment, construction, rubber processing, and the mining industry.

The new RKP-II is particularly well suited to applications where power, low noise and robust design, in combination with precision and speed are needed.

#### Low-noise and rugged design

With a number of innovative design features we have been able to reduce both the primary and the secondary noise level from the RKP-II. For sizes 32, 63 and 80 cm<sup>3</sup>/rev, the number of pistons have been increased from 7 to 9, reducing the working piston diameter leading to lower dynamic transverse forces acting on the housing. As a result the flow and pressure pulsations on the high pressure side have been reduced, enabling the RKP-II to help machine manufacturers comply with EU directive "2003/10/EC" on noise emissions.

In addition, in the RKP-II, the round stroke ring is replaced by a sliding stroke ring which is supported inside the pump housing (in certain sizes).

This minimizes wear on the internal pump components, even under the most demanding operating conditions, thereby extending the service life of the machine.

#### Digital or analogue control

The control technology of the RKP-II pump has been significantly improved with a new integral closed-loop proportional valve, with digital on-board electronics for flow and pressure regulation, tuning, and diagnostics.

The RKP-II can be digitally controlled via a CANopen interface or controlled by analogue command signals.

Details of the significant benefits available from running the RKP in either CANopen or analog modes are outlined in a separate catalogue for the RKP-D pump.

# RADIAL PISTON PUMPS RKP-II

## NEW DESIGN

### NEW DESIGN OVERVIEW

The new generation of RKP pumps, the RKP-II, benefits from reduced noise levels. They are now fitted with a sliding stroke ring and the suction flow path has been modified and increased in size preventing cavitation within the pump.

RKP-II stands for reliability, low noise, and durability and this is underlined by its extended warranty. Under the conditions described on page 6, warranty for mineral oil is covered for 10,000 operating hours or 24 months

### Further advantages of the Moog radial piston pump RKP-II are:

- Fast response
- Compact modular design enabling the pump selection to match the application
- Good suction characteristics
- Low pressure ripple

### The following RKP-II features are available:

- Medium pressure series (280 bar) and high pressure series (350 bar) for mineral oil
- Large selection of compensators including mechanical, hydraulic and electro-hydraulic (analog or digital with CAN bus)
- Mechanical flow limitation
- Multiple pumps by tandem mounting
- Various drive flanges
- Suitable for most hydraulic oils such as mineral oil, transmission oil, biodegradable oil and synthetic esters (HFD)
- Suitable pump versions are also available for special fluids such as oil in water emulsions, (HFA and HFB), water-glycol (HFC), lubricating oils and cutting emulsions. See the special fluids range of catalogues for details of these pumps.

### Mode of operation

The shaft (1) transfers the drive torque to the star-shaped cylinder block (3), free of any axial forces, via a crossdisc coupling (2). The cylinder block is hydrostatically supported on the control journal (4).

The radial pistons (5) in the cylinder block run against the stroke ring (7) through hydrostatically balanced slipper pads (6). The pistons and slipper pads are joined by ball and socket joints and locking rings.

The slipper pads are guided in the stroke ring by two retaining rings (8) and, when running, are held against the stroke ring by centrifugal force and oil pressure.

As the cylinder block rotates, the pistons reciprocate due to the eccentric positioning of the stroke ring, the piston stroke being twice the eccentricity.

The eccentric position of the stroke ring is controlled by two diametrically opposed control pistons (9, 10) and the pressure compensator (11). The oil flow to and from the pump passes through the pump ports and into and out of the pistons through the porting in the control journal.

The bearing supporting the drive shaft is only subjected to external forces

The compensator setting limits the system pressure and adjusts the pump flow between zero and full flow to maintain the set pressure.

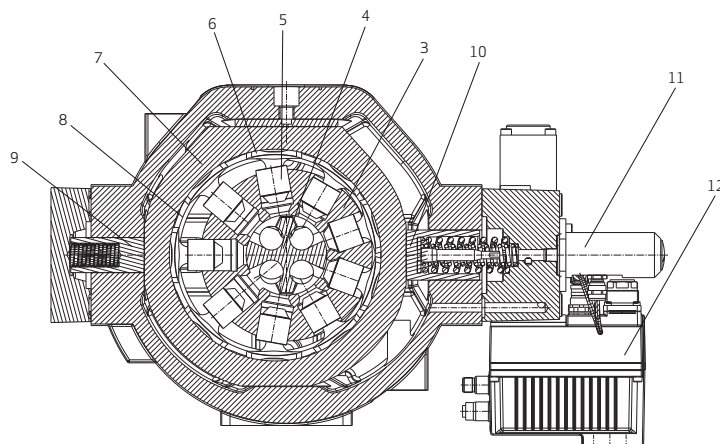
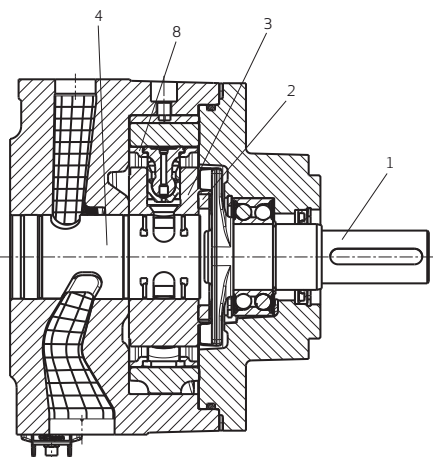

# RADIAL PISTON PUMPS RKP-II

## TECHNICAL DATA

Parameters								
Displacement [cm <sup>3</sup> /rev]	19	32	45	63	80	100	140	
Type of construction	Pump for open circuit with various control devices							
Type of mounting	End mounting, centering and hole-circle dia. to DIN/ISO 3019/2 (metric) Mounting flange to DIN/ISO 3019/1 (inch) Mounting flange to DIN/ISO 3019/2 (metric)							
Mounting position	Optional							
Weight [kg]	22	33	33	71	71	71	105	
Mass moment of inertia [kg cm <sup>2</sup> ]	17.7	61.0	61.0	186.3	186.3	186.3	380.0	
<b>Line connections:</b> according to ISO 6162 Medium pressure series 280 bar (4000psi) Pressure port	SAE 3/4" 3000 psi	SAE 1" 3000 psi	SAE 1" 3000 psi	SAE 1 1/4" 3000 psi	SAE 1 1/4" 3000 psi	SAE 1 1/4" 6000 psi	SAE 1 1/2" 6000 psi	
Suction port	SAE 3/4" 3000 psi	SAE 1 1/2" 3000 psi	SAE 1 1/2" 3000 psi	SAE 2" 3000 psi	SAE 2" 3000 psi	SAE 2" 3000 psi	SAE 2 1/2" 3000 psi	
High pressure serie 350 bar (5000 psi) Pressure port	SAE 3/4" 6000 psi	SAE 1" 6000 psi		SAE 1 1/4" 6000 psi	SAE 1 1/4" 6000 psi			
Suction port	SAE 3/4" 6000 psi	SAE 1 1/2" 3000 psi		SAE 2" 3000 psi	SAE 2" 3000 ps			
Recommended pipe OD for drain lines (lightweight version) [mm]	15 (5/8")	18 (3/4")	18 (3/4")	22 (7/8")	22 (7/8")	22 (7/8")	22 (7/8")	
Drain	The drain line is to be routed so that the pump housing is always full of the pumped fluid. The pressure at the drain port must not exceed 1 bar gauge pressure (2 bar absolute). The drain line to be piped directly to tank without filter, cooler, check valve etc. and must terminate below the minimum fluid level.							
Type of drive	Direct drive with coupling (please inquire from your Moog contact for other types)							
Ambient temperature range	-15 °C to +60 °C							
Max. speed at inlet pressure 0,8 bar abs. [min <sup>-1</sup> ] 1 bar abs. [min <sup>-1</sup> ]	2700 2900	2500 2900	1800 2100	2100 2300	1500 1800	1500 1800	1500 1800	
Max speed for quiet running [min <sup>-1</sup> ]	1800	1800	1800	1800	1800	1800	1800	
Min. inlet pressure suction connection	0.8 bar absolute							
Max. housing pressure	2 bar (1 bar gauge pressure)							
Medium pressure series Continuous pressure max. pressure <sup>1)</sup> [bar] Pressure peak	280 315 350	280 315 350	280 315 350	280 315 350	280 315 350	280 315 350	280 315 350	
High pressure series Continuous pressure max. pressure <sup>1)</sup> [bar] Pressure peak	350 385 420	350 385 420		350 385 420	350 385 420			
Hydraulic fluid	Mineral oil to DIN 51 524							
Hydraulic fluid temperature range	-15 °C to +80 °C							
Viscosity	Allowable operational range 12 to 100 mm <sup>2</sup> /s (cSt); recommended 16 to 46 mm <sup>2</sup> /s (cSt) Hydraulic fluid according to viscosity class ISO VG 46 or VG 32 Max. viscosity 500 mm <sup>2</sup> /s during start-up with electric motor at 1800 min <sup>-1</sup>							
Filtering	NAS 1638, class 9; ISO/DIN 4406, class 20/18/15; obtained with filter fineness of β <sub>20</sub> = 75 <sup>2)</sup>							

For special fluids e.g., HFA, HFC and emulsions the above pressure, viscosity and filtration parameters may be changed.  
See the relevant special fluids catalogue for details.

<sup>1)</sup> Max. pressure to DIN 24 312

<sup>2)</sup> Dirt particles retention rate > 20 μm is 1: 75, i.e. 98,67 %

1000 psi = 70 bar

# RADIALKOLBENPUMPEN RKP-II

## PERFORMANCE CURVES

### ADJUSTMENT RANGE

#### ⚠ Caution

The rotation of the pump cannot be changed

#### Clockwise rotation

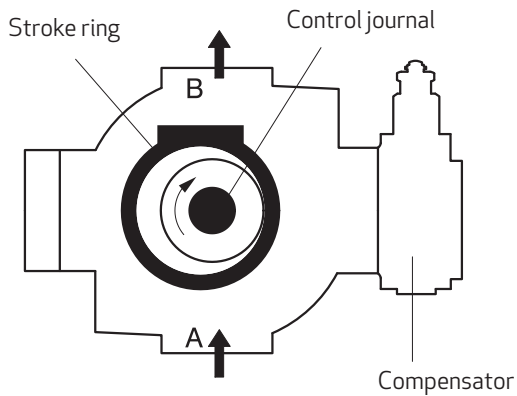

#### Counter-clockwise rotation

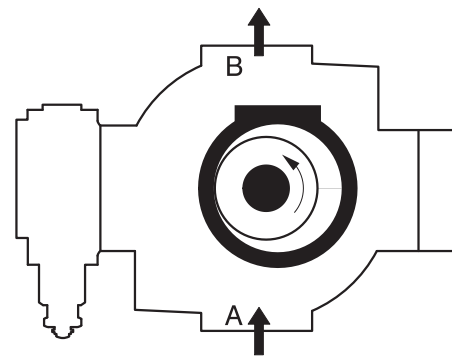

### Power consumption P

at maximum flow  
hydraulic fluid: mineral oil  
viscosity  $\nu = 35 \text{ mm}^2/\text{s}$  [cSt]  
temperature  $T = 50 \text{ }^\circ\text{C}$

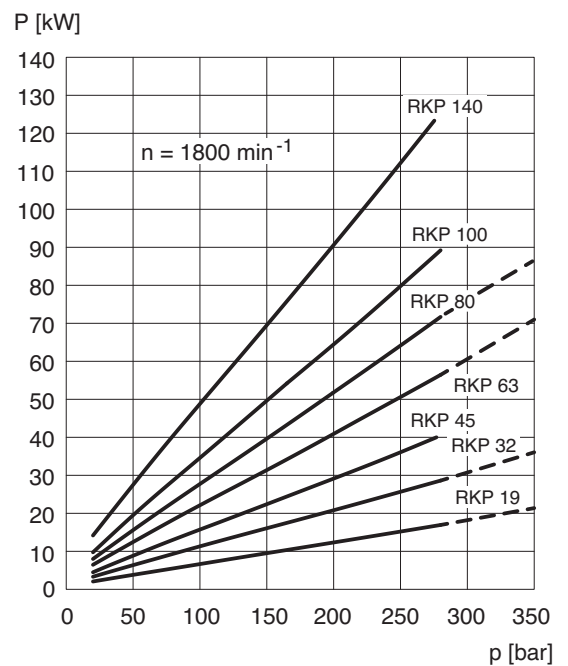
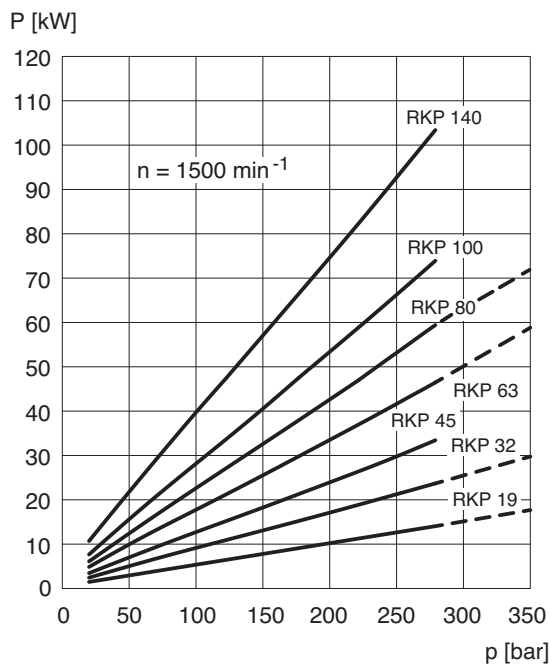

———— Standard version

----- High-pressure version

# RADIAL PISTON PUMPS RKP-II

## PERFORMANCE CURVES

### NOISE DIAGRAM

$n = 1500 \text{ min}^{-1}$  at  $Q_{\text{max}}$

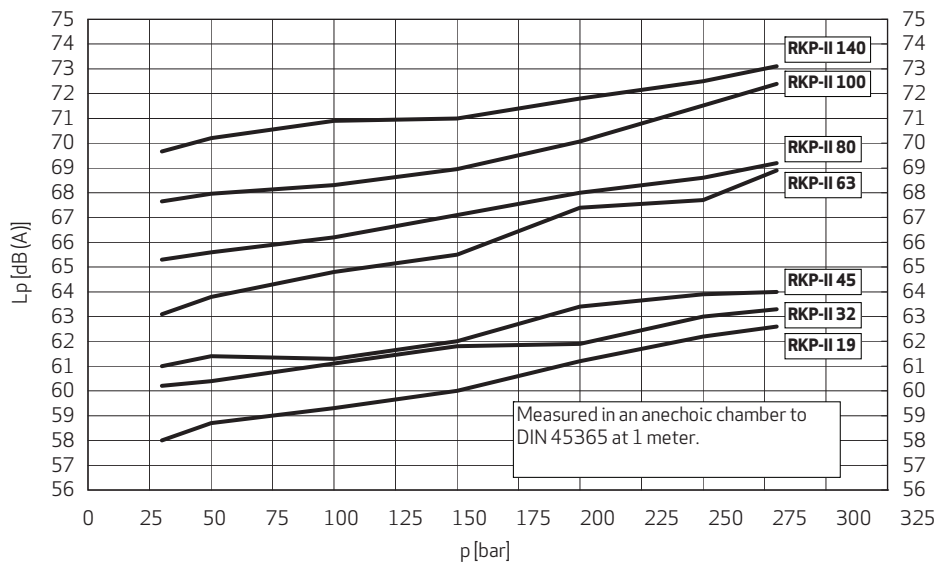

Noise emission values with combined pressure/flow compensator. These are average values over the operating range.

### Performance curves of drive power and displacement

Response time  $V_{\text{max.}} \rightarrow V_{\text{min.}}$ : 20 to 50 ms (approx. value)

Response time  $V_{\text{min.}} \rightarrow V_{\text{max.}}$ : 50 to 100 ms  
from 70 bar pressure setting (approx. value)

$n = 1500 \text{ min}^{-1}$ ;  $\nu = 35 \text{ mm}^2/\text{s}$ ;  $T = 50 \text{ }^\circ\text{C}$  (122  $^\circ\text{F}$ )

$V = 19 \text{ cm}^3/\text{rev}$

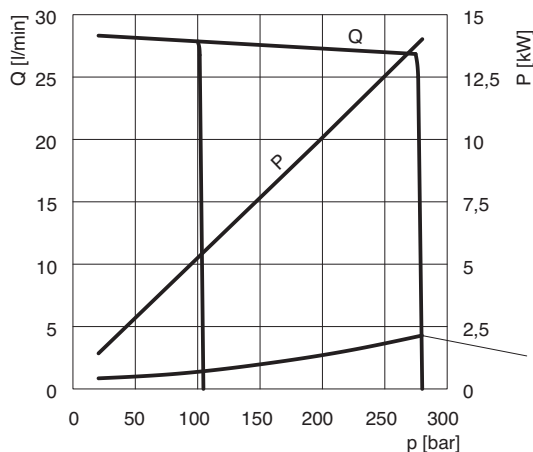

$V = 32 \text{ cm}^3/\text{rev}$

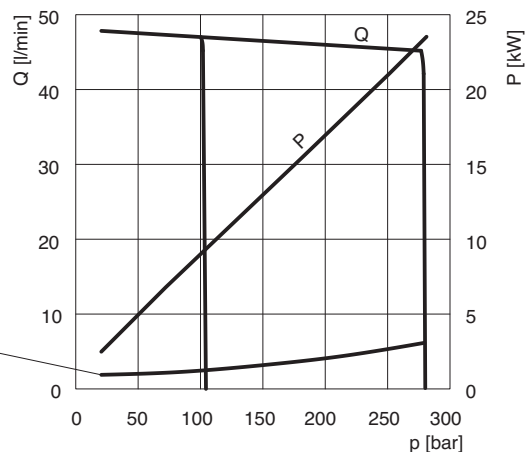



# RADIAL PISTON PUMPS RKP-II

## PERFORMANCE CURVES

**V = 45 cm<sup>3</sup>/rev**

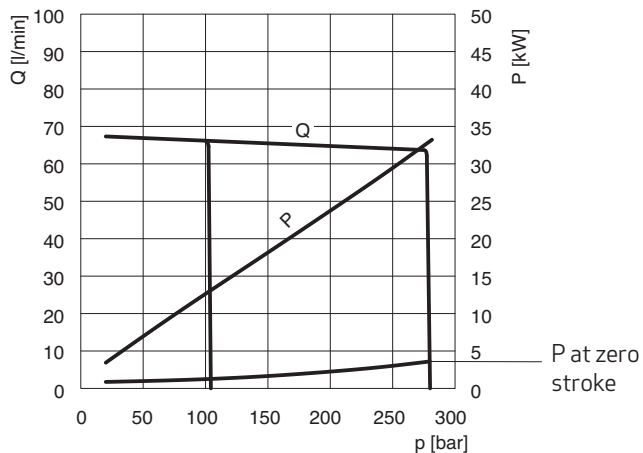

**V = 63 cm<sup>3</sup>/rev**

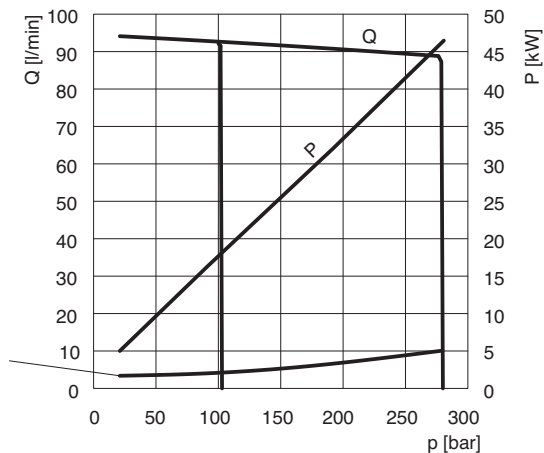

**V = 80 cm<sup>3</sup>/rev**

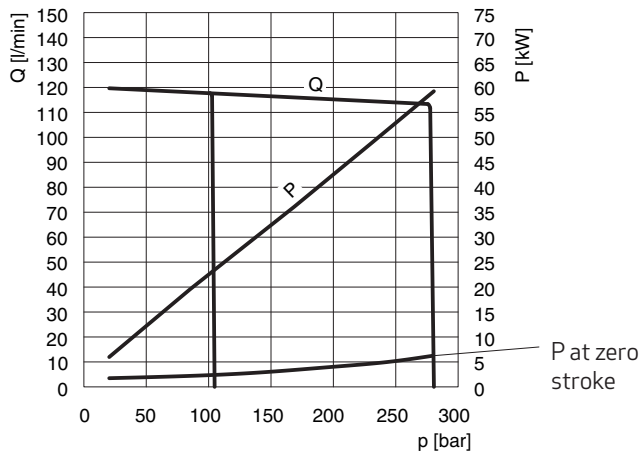

**V = 100 cm<sup>3</sup>/rev**

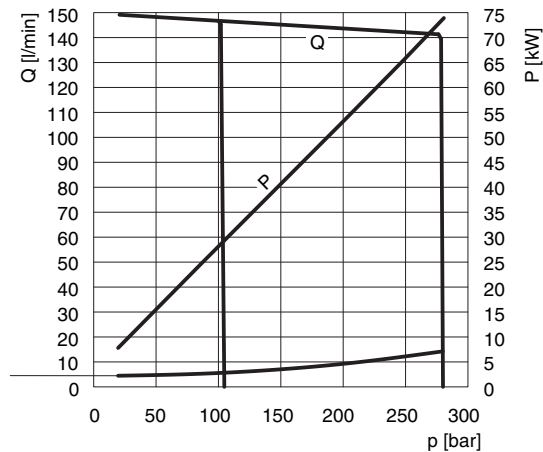

**V = 140 cm<sup>3</sup>/rev**

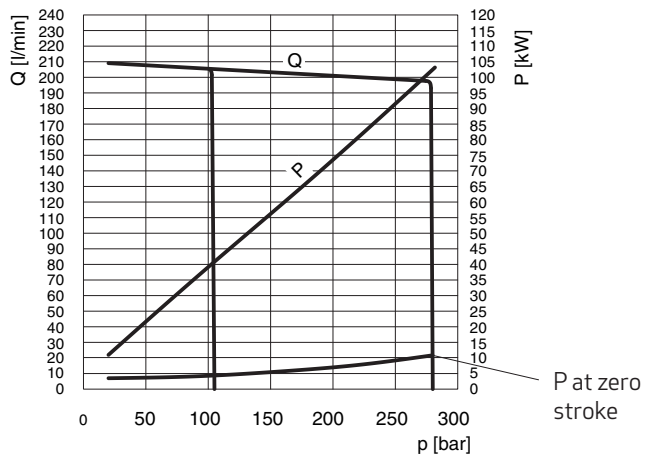

# RADIAL PISTON PUMPS RKP-II

## COMPENSATOR OPTIONS

### COMPENSATOR OPTIONS

RKP-II enables a variety of compensator options to be used thereby ensuring maximum flexibility. The following options are described in more detail in appendix A.

Compensator option, Model code	Description/characteristics/application
<b>1. Adjustable pressure compensator, Type F</b>	For constant pressure systems with a fixed pressure setting
<b>2. Remote pressure compensator, Type H1</b>	For constant or variable pressure systems with remote pressure setting
<b>3. Pressure compensator with Mooring control, Type H2</b>	For constant pressure systems with a variable pressure setting for mooring control
<b>4. Combined pressure and flow compensator, Type J</b>	For displacement systems with a variable flow and load sensing pressure control
<b>5. Combined pressure and flow compensator with p-T control notch, Type R</b>	As 4. with additional active reduction of pressure peaks in the event of dynamic control processes
<b>6. Mechanical stroke adjustment, Type B1</b>	For displacement systems with a fixed displacement that may be manually adjusted as needed
<b>7. Servo control, Type C1</b>	Adjustment of displacement using a hand lever or an actuator
<b>8. Constant horse-power control (force comparison system), Type S1</b>	Automatic reduction of displacement in the event of an increasing load so that the capacity of the drive motor is not exceeded
<b>9. Constant horsepower control with remote pressure and flow control, Type S2</b>	As 8. but with additional adjustable maximum limit for pressure and flow
<b>10. Electro-hydraulically adjustable compensator with digital on-board electronics, Type D</b>	For displacement systems with variable flow and/or pressure limitation

# RADIAL PISTON PUMPS RKP-II

## MULTIPLE ARRANGEMENTS

### RKP MULTIPLE ARRANGEMENTS

Additional pumps can be tandem mounted on the radial piston pump, so that all pump stages can be driven by the same shaft. Radial piston pumps (the same size or smaller than the first pump stage) can be mounted directly.

Other pumps may be added on using adapter flanges for SAE-A and SAE-B respectively (see page 13/14). For the maximum permitted through-drive torque for driving add-on pumps, please refer to the table below.

### Adding on RKP, SAE-A or SAE-B adapters Permissible through-drive torques

Pump stage 1	Pump stage 2				SAE-A	SAE-B
RKP-II	RKP-II					
Size (cm <sup>3</sup> /rev)	19	32 45	63 80 100	140		
19	90 Nm	-	-	-	90 Nm	-
32/45	185 Nm	185 Nm	-	-	110 Nm	185 Nm
63/80/100	400 Nm	400 Nm	400 Nm	-	110 Nm	280 Nm
140	400 Nm	400 Nm	400 Nm	620 Nm	110 Nm	280 Nm

The through-drive torque required to drive add-on pumps is determined by reference to the following variables:

V [cm<sup>3</sup>/rev] Displacement  
 p [bar] Pressure  
 $\eta_{hm}$  [%] Hydro-mechanical efficiency  
 M [Nm] Through-drive torque

Through-drive torque from pump stage 1 to 2:

$$M_1 = 1,59 \cdot \sum_{i=2}^n \frac{V_i \cdot p_i}{\eta_{hmi}}$$

1 Nm = 8.85 lbf. in  
 1 bar = 14.5 psi

### Example

If we take the following pump combination  
 RKP 63 + RKP 63 + RKP 32 + AZP 16  
 280 bar, 210 bar, 150 bar, 50 bar,  
 the following considerations apply:

### Design of 1st through-drive

The pressure and flow of the 1st pump stage are irrelevant to the torque transferred by the through-drive. This torque can be calculated using the above formula.

$$M_1 = 1,59 \cdot \left( \frac{V_2 \cdot p_2}{\eta_{hm2}} + \frac{V_3 \cdot p_3}{\eta_{hm3}} + \frac{V_4 \cdot p_4}{\eta_{hm4}} \right)$$

$$M_1 = 1,59 \cdot (63 \cdot 210 / 95 + 32 \cdot 150 / 93 + 16 \cdot 50 / 90) \text{ Nm}$$

$$M_1 = 318 \text{ Nm}$$

The value 318 Nm is below the threshold value of 400 Nm specified in the above table for mounting an RKP 63 on another RKP 63.

### Design of 2nd through-drive torque

$$M_2 = 1,59 \cdot \left( \frac{V_3 \cdot p_3}{\eta_{hm3}} + \frac{V_4 \cdot p_4}{\eta_{hm4}} \right)$$

$$M_2 = 1,59 \cdot (32 \cdot 150 / 93 + 16 \cdot 50 / 90) \text{ Nm}$$

$$M_2 = 96 \text{ Nm}$$

Likewise, the value 96 Nm lies below the relevant threshold value of 400 Nm for the through-drive from RKP-II 63 to an RKP-II 32.

### Design of 3rd through-drive torque

Similarly, a value of 14 Nm is obtained for the torque required to drive the add-on gear pump. Thus, the through-drives for this pump combination are permissible with the stated pressures.

# RADIAL PISTON PUMPS RKP-II

## MULTIPLE ARRANGEMENTS

Radial piston pump with heavy-duty through-drive and tandem mounted radial piston pump

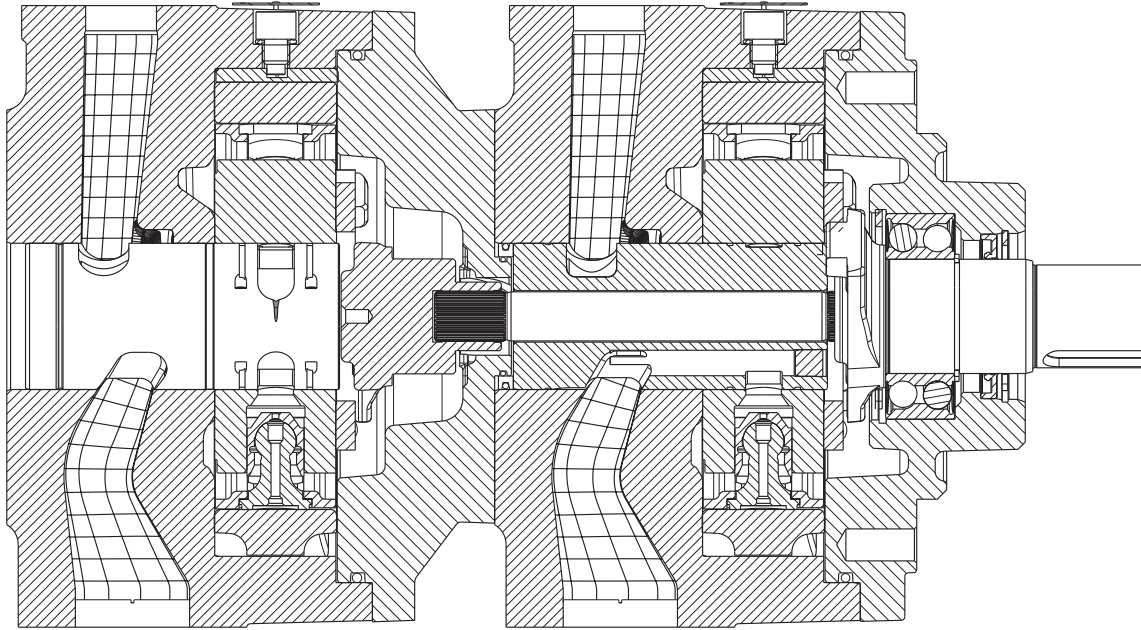

Radial piston pump with tandem mounted gear pump using SAE-A adapter

Radial piston pump with tandem mounted gear pump using SAE-B adapter

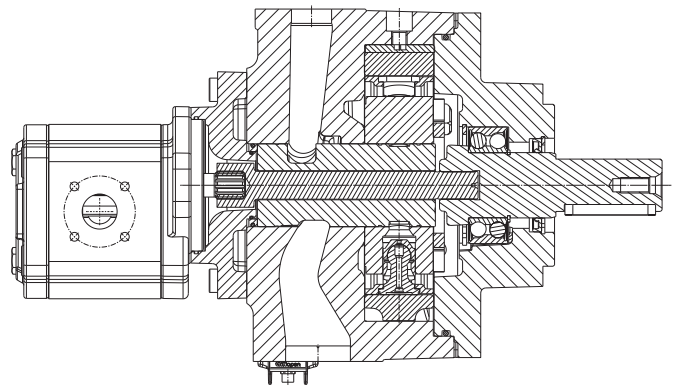
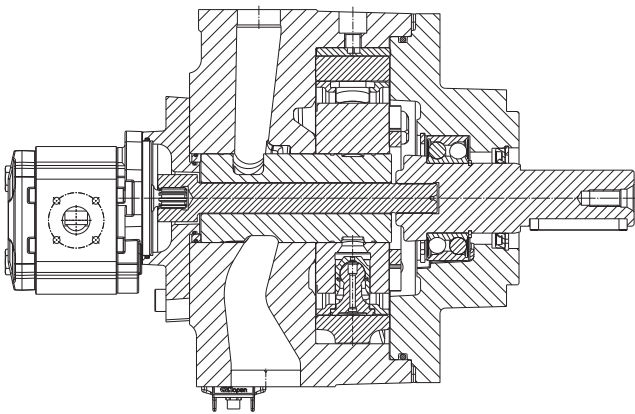

# RADIAL PISTON PUMPS RKP-II

## MULTIPLE ARRANGEMENTS

### ADAPTOR FLANGE FOR FITTING AN EXTERNAL PUMP USING FLANGE SAE-A ACCORDING TO ISO 3019-1 AND 9-TOOTH SHAFT

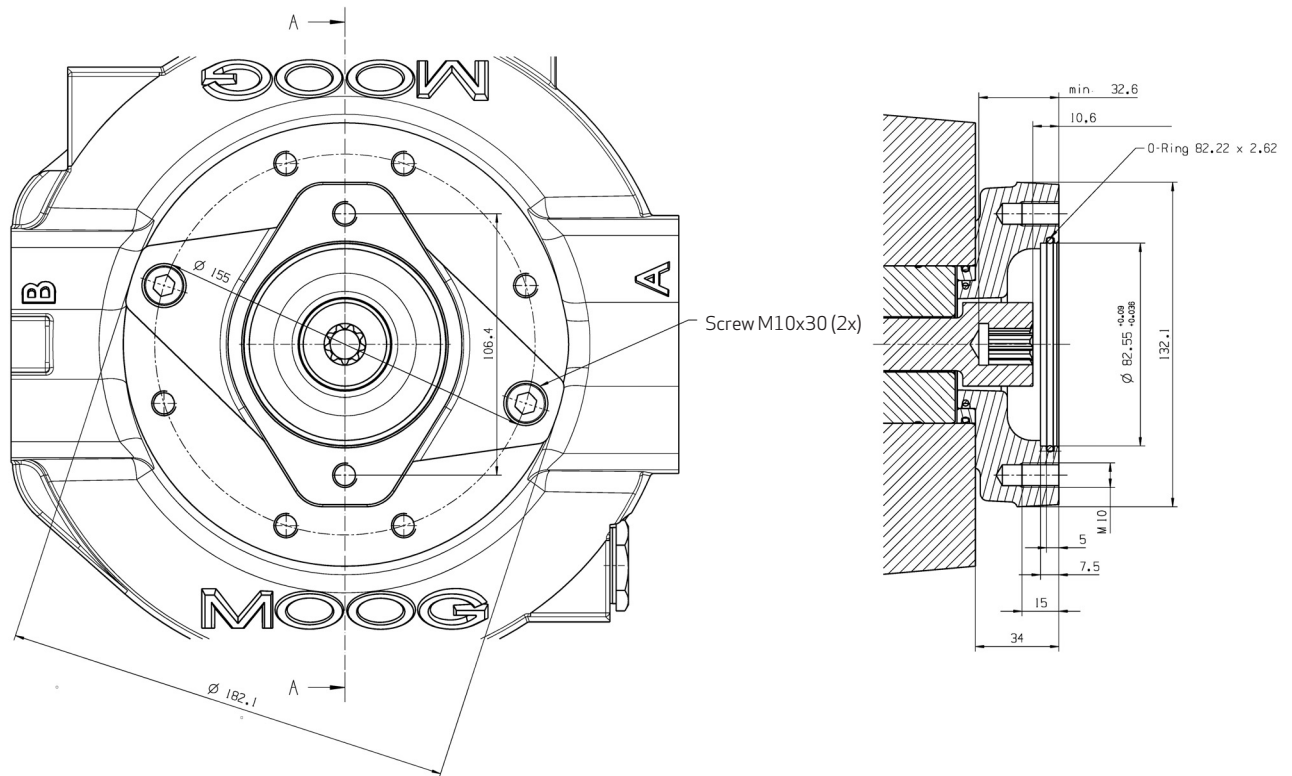

**Flange code:** 82-2

**Shaft code:** 16-4

**Toothing to:** ANSI B92.1 9T 16/32 DP Flat root side fit

**Conditions for attachment:**  
RKP with heavy-duty through-drive

Adaptor including through-drive shaft, seals (HNB-R), intermediate ring for RKP 63-140 and 2 fastening screws.

RKP 19	<b>CA41832-001</b>
RKP 32/45	<b>CA51553-001</b>
RKP 63/80/100	<b>CA64727-001</b>
RKP 140	<b>CA64728-001</b>

# RADIAL PISTON PUMPS RKP-II

## MULTIPLE ARRANGEMENTS

### ADAPTOR FLANGE FOR FITTING AN EXTERNAL PUMP USING FLANGE SAE-B ACCORDING TO ISO 3019-1 AND 13-TOOTH SHAFT

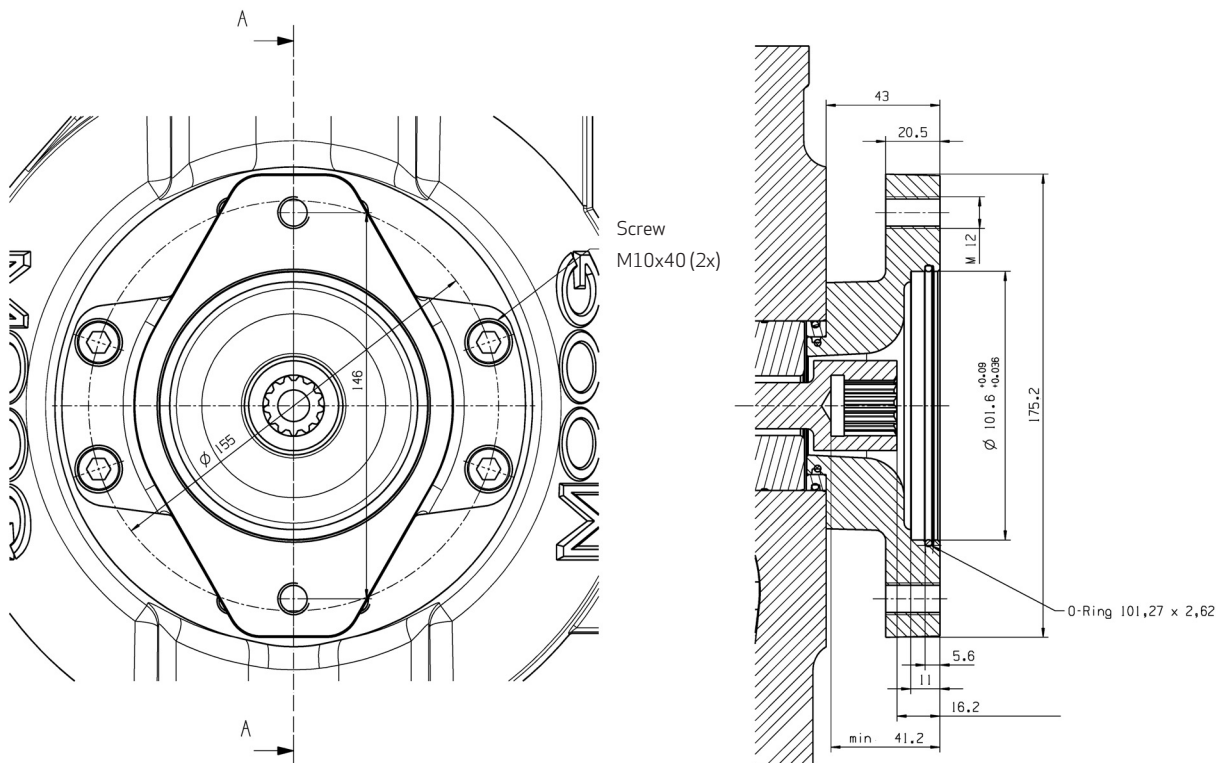

**Flange code:** 101-2

**Shaft code:** 22-4

**Toothing to:** ANSI B92.1 13T 16/32 DP Flat root side fit

**Conditions for attachment:**  
RKP with heavy-duty through-drive

Adaptor including through-drive shaft, seals (HNB-R), intermediate ring for RKP 63-140 and 4 fastening screws.

RKP 32/45	<b>CA36273-001</b>
RKP 63/80/100	<b>CA34793-001</b>
RKP 140	<b>CA50487-001</b>

# RADIAL PISTON PUMPS RKP-II

## MODEL CODE

### THE MODEL CODE DESCRIBES PUMP OPTIONS

There are design interfaces (flange, shaft end and ports), hydraulic parameters (volume flow, operating pressure) and hydraulic fluid) and control options.

### EXAMPLE

Pos. No.	1	2	3	4				
Drive	HP	-	R	18	B1	-		
Pos. No.	5	6	7	8	9	10	11	12
Pump 1	RKP	100	T	M	28	D1	Z	00
Pump 2	RKP	063	K	M	28	D2	Z	00
Pump 3	AZP	008	R	M	28	TP	0	00

Pos.	Drive				Radial Piston Pump							
	1	2	3	4	5	6	7	8	9	10	11	12
Sym.	HP	R	18	B1	RKP	100	T	M	28	D1	Z	00
Pos.	Radial Piston Pump											
	5	6	7	8	9	10	11	12				
Sym.	RKP	063	K	M	28	D2	Z	00				
Pos.	Additional Pump Stage											
	5	6	7	8	9	10	11	12				
Sym.	AZP	008	R	M	28	TP	0	00				

Pos.	Sym.	Drive
1	HP HK HZ	<b>Code</b> <b>Hydraulic Pump</b> Explosion protection pump (ATEX) Pump with special features
2	R L	<b>Rotations</b> <b>Clockwise, looking at drive shaft</b> Counterclockwise, looking at drive shaft
3	18	<b>Speed</b> max. speed for low noise operation or rated speed for power controlled pumps e.g. 18 = n = 1800 min <sup>-1</sup>
4	A1 B1 A7 B7 C3 D3 A5 C6 XX	<b>Drive flange</b> Straight key according to DIN 6885, metric round flange (not for RKP 140) Spline according to DIN 5482, metric round flange (not for RKP 140) Straight key according to DIN 6885, 4 holes ISO flange according to DIN ISO 3019/2 (metric) Spline according to DIN 5480, 4 holes ISO flange according to DIN ISO 3019/2 (metric) Straight key according to SAE 744 C, 2/4 holes SAE-flange according to DIN ISO 3019/1 (inch) Spline according to SAE 744 C (ISO 3019/1), 2/4 holes SAE-flange according to DIN ISO 3019/1 (inch) Straight key according to DIN 6885, metric round flange for polyurethane foam Straight key according to SAE 744 C, 2/4 holes SAE-flange according to DIN ISO 3019/1 (inch) for polyurethane foam Intermediate flange RKP/RKP

# RADIAL PISTON PUMPS RKP-II

## MODEL CODE

Pos.	Sym.	Radial Piston Pump																				
5	RKP AZP  DS1	<p><b>Pump type</b> Radial piston pump, variable displacement Moog gear pump with SAE-A and SAE-B flange</p> <p><b>Attachment of other pumps</b> Heavy-duty through-drive for RKP attachment and adapter flange for SAE-A and SAE-B</p>																				
6	019 032 045 063 080 100 140  005 008 011 016 019 023 031 033 044 050	<p><b>Displacement RKP-II</b> 19 cm<sup>3</sup>/rev 32 cm<sup>3</sup>/rev 45 cm<sup>3</sup>/rev 63 cm<sup>3</sup>/rev 80 cm<sup>3</sup>/rev 100 cm<sup>3</sup>/rev 140 cm<sup>3</sup>/rev</p> <p><b>Displacement and attachment flange of Moog gear pumps (AZP)</b></p> <table> <tr> <td>5 cm<sup>3</sup>/rev</td> <td>SAE-A</td> </tr> <tr> <td>8 cm<sup>3</sup>/rev</td> <td>SAE-A</td> </tr> <tr> <td>11 cm<sup>3</sup>/rev</td> <td>SAE-A</td> </tr> <tr> <td>16 cm<sup>3</sup>/rev</td> <td>SAE-A</td> </tr> <tr> <td>19 cm<sup>3</sup>/rev</td> <td>SAE-A</td> </tr> <tr> <td>23 cm<sup>3</sup>/rev</td> <td>SAE-A</td> </tr> <tr> <td>31 cm<sup>3</sup>/rev</td> <td>SAE-A</td> </tr> <tr> <td>33 cm<sup>3</sup>/rev</td> <td>SAE-B</td> </tr> <tr> <td>44 cm<sup>3</sup>/rev</td> <td>SAE-B</td> </tr> <tr> <td>50 cm<sup>3</sup>/rev</td> <td>SAE-B</td> </tr> </table>	5 cm <sup>3</sup> /rev	SAE-A	8 cm <sup>3</sup> /rev	SAE-A	11 cm <sup>3</sup> /rev	SAE-A	16 cm <sup>3</sup> /rev	SAE-A	19 cm <sup>3</sup> /rev	SAE-A	23 cm <sup>3</sup> /rev	SAE-A	31 cm <sup>3</sup> /rev	SAE-A	33 cm <sup>3</sup> /rev	SAE-B	44 cm <sup>3</sup> /rev	SAE-B	50 cm <sup>3</sup> /rev	SAE-B
5 cm <sup>3</sup> /rev	SAE-A																					
8 cm <sup>3</sup> /rev	SAE-A																					
11 cm <sup>3</sup> /rev	SAE-A																					
16 cm <sup>3</sup> /rev	SAE-A																					
19 cm <sup>3</sup> /rev	SAE-A																					
23 cm <sup>3</sup> /rev	SAE-A																					
31 cm <sup>3</sup> /rev	SAE-A																					
33 cm <sup>3</sup> /rev	SAE-B																					
44 cm <sup>3</sup> /rev	SAE-B																					
50 cm <sup>3</sup> /rev	SAE-B																					
7	K T  S H R	<p><b>Pump ports</b> <b>Medium pressure series (to 280 bar) sizes 32, 45, 63 and 80 cm<sup>3</sup>/rev</b> <b>Medium pressure series (to 280 bar) sizes 100 and 140 cm<sup>3</sup>/rev</b> High pressure series (to 350 bar) sizes 32, 63 and 80 cm<sup>3</sup>/rev <b>Medium pressure series (to 280 bar) size 19 cm<sup>3</sup>/rev</b> High pressure series (to 350 bar) size 19 cm<sup>3</sup>/rev German 4 bolt flange (only for gear pumps)</p>																				
8	M A B C D E	<p><b>Operating fluid</b> <b>Mineral Oil</b> HFA (oil in water) HFB (oil in water) HFC (water glycol) HFD (synthetic ester) Cutting Emulsion</p>																				
9	28 35	<p><b>Operating pressure</b> <b>Maximum operating pressure e.g., = 280 bar = 28</b> Maximum operating pressure e.g., = 350 bar = 35</p>																				



# RADIAL PISTON PUMPS RKP-II

## MODEL CODE

Pos.	Sym.	Radial Piston Pump
10	B1 C1 <b>D1</b> <sup>1</sup> <b>D2</b> <sup>1</sup> D3 <sup>1</sup> D4 <sup>1</sup> D5 <sup>1</sup> D6 <sup>1</sup> D7 <sup>1</sup> D8 <sup>1</sup> <b>F1</b> <b>F2</b> G1 G2 <b>H1</b> H2 <b>J1</b> J2 <b>R1</b> S1 S2 S3 TP	<p><b>Control/Compensators</b></p> <p>Mechanical stroke adjustment (V = constant)</p> <p>Servo control</p> <p><b>RKP-D (electro-hydraulic control with digital on-board electronics), analog or digital activation and internal pressure supply</b></p> <p><b>RKP-D (electro-hydraulic control with digital on-board electronics), analog or digital activation and external pressure supply</b></p> <p>RKP-D with external pressure supply, useable for hybrid operation</p> <p>RKP-D with internal pressure supply, useable for hybrid operation</p> <p>RKP-D with internal pressure supply useable for master/slave operation</p> <p>RKP-D with external pressure supply useable for master/slave operation</p> <p>RKP-D with external pressure supply useable for master/slave and hybrid operation</p> <p>RKP-D with internal pressure supply useable for master/slave and hybrid operation</p> <p><b>Pressure compensator, adjustable from 30 - 105 bar</b></p> <p><b>Pressure compensator, adjustable from 80 - 350 bar</b></p> <p>Pressure compensator, adjustable and lockable, from 30 - 105 bar</p> <p>Pressure compensator, adjustable and lockable, from 80 - 350 bar</p> <p><b>Pressure compensator, hydraulically controlled</b></p> <p>Mooring control</p> <p><b>Combined pressure and flow compensator <math>\Delta p = 10</math> bar</b></p> <p>Combined pressure and flow compensator <math>\Delta p = 20</math> bar</p> <p><b>Combined pressure and flow compensator with P-T control notch</b></p> <p>Constant horsepower control</p> <p>Constant horsepower control with pressure-flow limitation, <math>\Delta p = 10</math> bar</p> <p>Constant horsepower control with pressure-flow limitation, <math>\Delta p = 20</math> bar</p> <p>Gear pump</p>
11	<b>Z</b> Y 0	<p><b>Additional equipment</b></p> <p><b>No Accessories</b></p> <p>Maximum flow limiter</p> <p>Only at gear pump</p>
12	00 <b>01</b>  04 05 07 11 15 18 22 30 37 45  05 ... 50	<p><b>Additional information</b></p> <p>For Compensators D1 ... D8</p> <p>Actual value 4 ... 20 mA</p> <p><b>Actual value 2 ... 1 0 V</b></p> <p><b>For compensators S1, S2, S3 output P for specified speed</b></p> <p>4 kW (RKP 32)</p> <p>5,5 kW (RKP 32)</p> <p>7,5 kW (RKP 32, 63)</p> <p>11 kW (RKP 32, 63)</p> <p>15 kW (RKP 32, 63, 100)</p> <p>18 kW (RKP 63, 100)</p> <p>22 kW (RKP 63, 100)</p> <p>30 kW (RKP 63, 100)</p> <p>37 kW (RKP 100)</p> <p>45 kW (RKP 100)</p> <p><b>For tandem gear pumps:</b></p> <p>Displacement of the 2nd gear pump</p> <p>5 ... 50 cm<sup>3</sup>/rev</p>

<sup>1</sup> See catalog RKP with digital control (RKP-D)

Options may increase price. Not all combinations may be available.

Preferred configurations are highlighted. Subject to change.

# RADIAL PISTON PUMPS RKP-II

## TECHNICAL INFORMATION

---

### TECHNICAL INFORMATION

#### △ Important

The pump must be put into service by a trained hydraulic systems engineer.

#### Installation

The radial piston pump can be mounted in any position. The drive shaft must not be subject to radial or axial loads and should therefore be driven through a flexible coupling. The pump must be driven in the correct direction of rotation.

All plugs on the pump should only be removed immediately before the pipes are connected and standard hydraulic cleanliness procedures to be used.

The use of cold drawn seamless steel pipes in accordance with DIN 2391 is recommended.

#### Suction line (A)

It is recommended that final piping connections to the pump are flexible hoses. The shortest possible suction line should be used with a diameter large enough to give a fluid velocity below 1.5 m/sec.

Sharp angles and screwed pipe joints should be avoided due to the danger of air ingress and excessive pressure drop therefore, pipe bends and/or hoses should be used. The minimum permissible inlet pressure must be maintained. If a suction filter (min. 0.15 mm mesh aperture) or an isolating valve is to be used, it must be installed below the fluid level.

#### Pressure line (B)

Ensure the pressure pipework is securely clamped and the screws are correctly torque tightened.

#### Drain line (L)

The upper drain port must be used for the drain line and the pipework is to be routed to ensure the housing is always full of fluid. The pipe should lead directly to the tank, separate from other return lines.

It must terminate below the lowest fluid level and should be as far away from the suction take off as possible.

Do not fit a filter, cooler or non-return valve in the drain line. The maximum recommended length for the drain line is 3 metres ( 10 ft.).

The pressure at drain port is not to exceed 1 bar gauge ( 14.5 psi ) (2 bars absolute ( 29 psi )).

The recommended outside pipe diameters for drain lines (lightweight version) are:

RKP 19: 15 mm (5/8")

RKP 32 and 45: 18 mm (3/4")

RKP 63, 80, 100 and 140: 22 mm (7/8").

#### Flushing the housing

If the pump is operated at low pressure without flow for long periods ( $t > 15$  min,  $p < 30$  bar ( 435 psi ),  $Q = 0$  l/min), pump sizes 63 ... 100 cm<sup>3</sup>/rev must be flushed with approx. 4 ... 6 l/min ( 1 ... 1.5 US gal/min) to dissipate the heat generated. The 140 cm<sup>3</sup>/rev pump must always be flushed with 6 ... 8 l/min ( 1.5 ... 2 US gal/min ). The flushing line to the pump must be connected to the lower drain port

#### Noise development

Radial piston pumps have a low primary noise level. However, the overall noise level hydraulic of the unit depends on the pump mounting and piping layout and the transmitted noise can be prevented by:

- connecting the pump to the bellhousing using an anti-vibration flange.
- use flexible hoses instead of solid pipes.
- clamp the pipework with elastic insert clamps.

#### Connections

Suction line to port A and pressure line from port B. Except for RKP 19 counterclockwise: suction port B, pressure port A.

#### Putting into service

Do not start up the pump without hydraulic fluid. Before switching on, the pump housing must be filled with hydraulic fluid using the higher drain port.

Jog start the electric motor to check the correct direction of rotation. Run the pump at low pressure until the hydraulic system has been fully de-aerated. When putting pumps for HF fluids into operation, the system must be run at low pressure of between 30 ... 50 bar ( 435 ... 725 psi ) for approximately 1 hour.

#### Important

The oil temperature in the tank must not exceed the temperature of the pump by more than 25° C ( 77° F ).

If this should occur, the pump must be jog started for intervals of approximately 1 to 2 seconds until pump casing has heated up.

When changing a pump, clean the suction pipe, drain line and tank. Refill the tank with filtered oil.

# RADIAL PISTON PUMPS RKP-II

## APPENDIX A – COMPENSATOR OPTIONS

### 1. ADJUSTABLE PRESSURE COMPENSATOR F1, F2

Pressure range  
F1: 30 ... 105 bar  
F2: 80 ... 350 bar

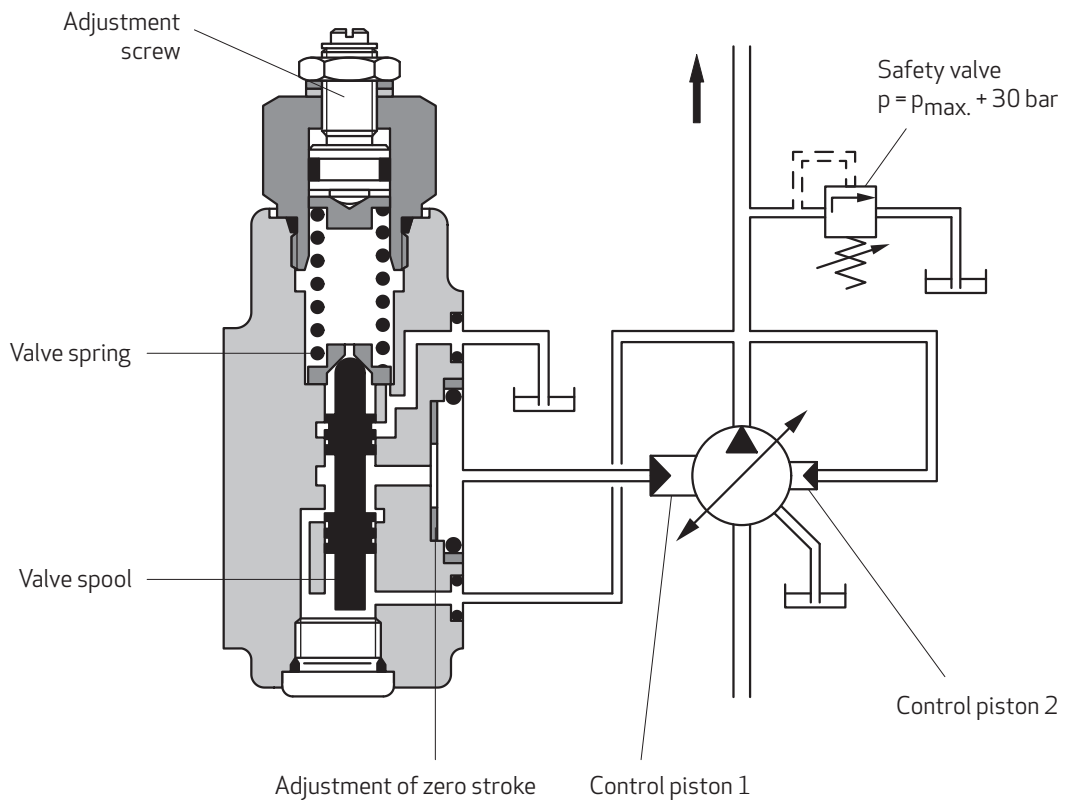
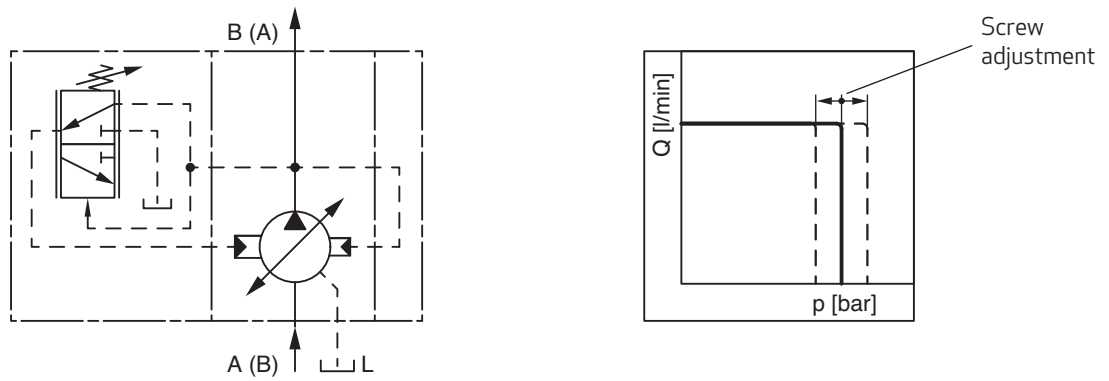

# RADIAL PISTON PUMPS RKP-II

## APPENDIX A – COMPENSATOR OPTIONS

### 2. REMOTE PRESSURE COMPENSATOR H1

Pressure pilot valve

$Q = 0.5 \dots 1.5 \text{ l/min}$

manual remote adjustable or proportional pressure valve

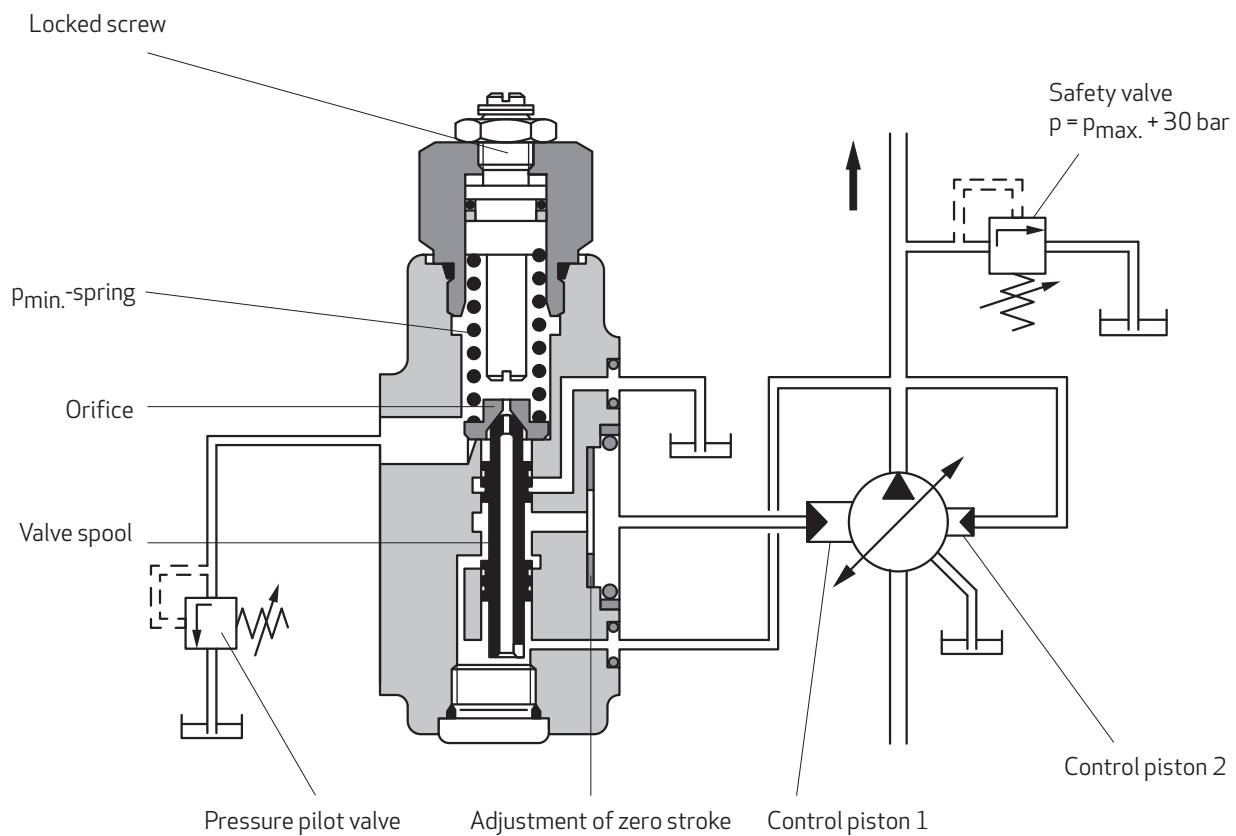
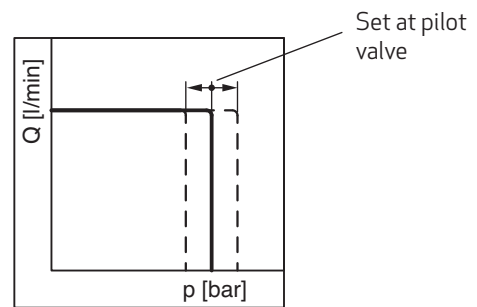
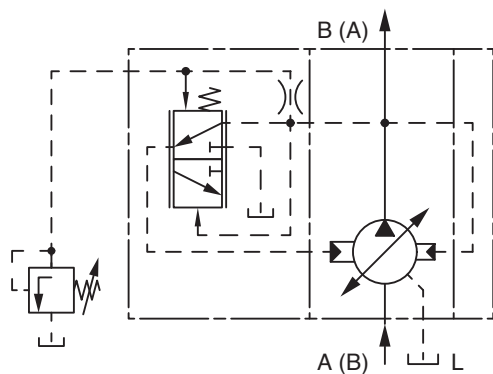

# RADIAL PISTON PUMPS RKP-II

## APPENDIX A – COMPENSATOR OPTIONS

### 3. REMOTE PRESSURE COMPENSATOR WITH MOORING CONTROL H2

The "Mooring" control consists of a pressure compensator which has an intermediate plate inserted between the pump body and the pressure compensator.

The thickness of the intermediate plate corresponds to the eccentricity of the stroke ring.

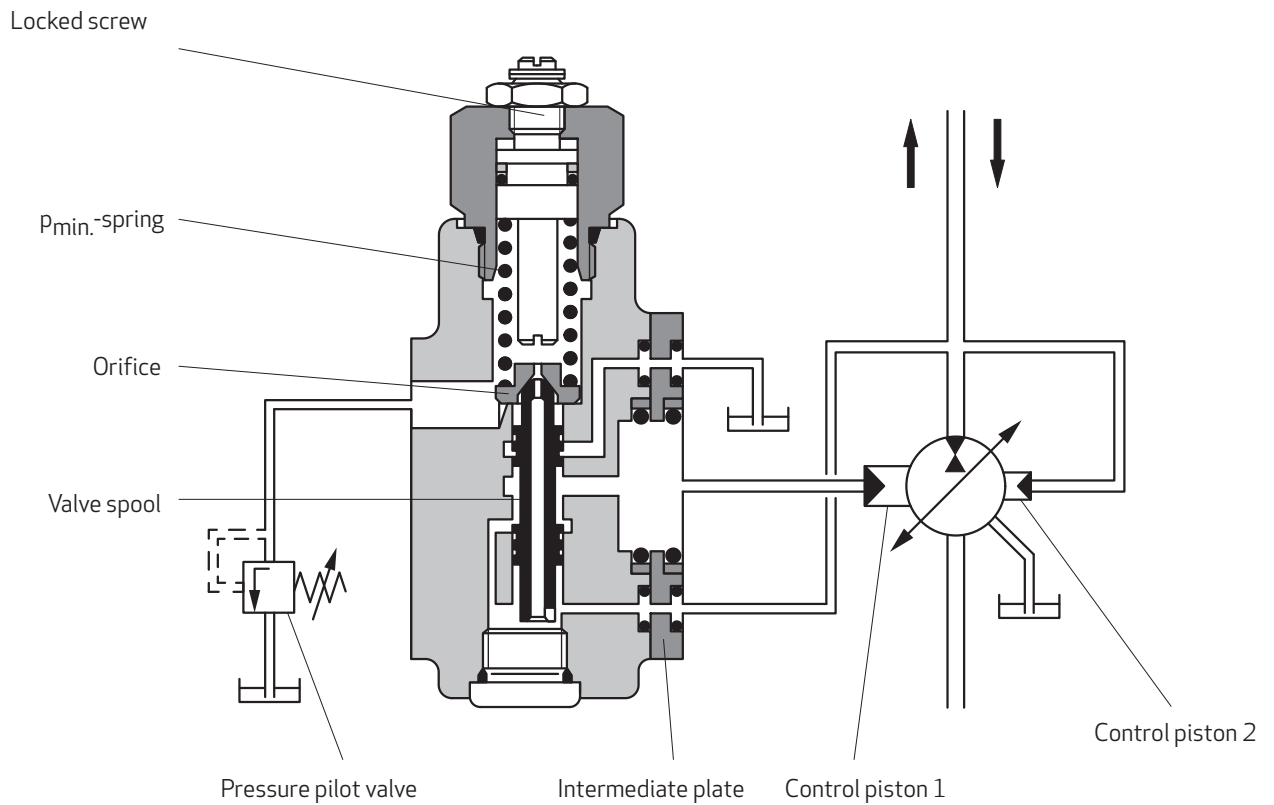
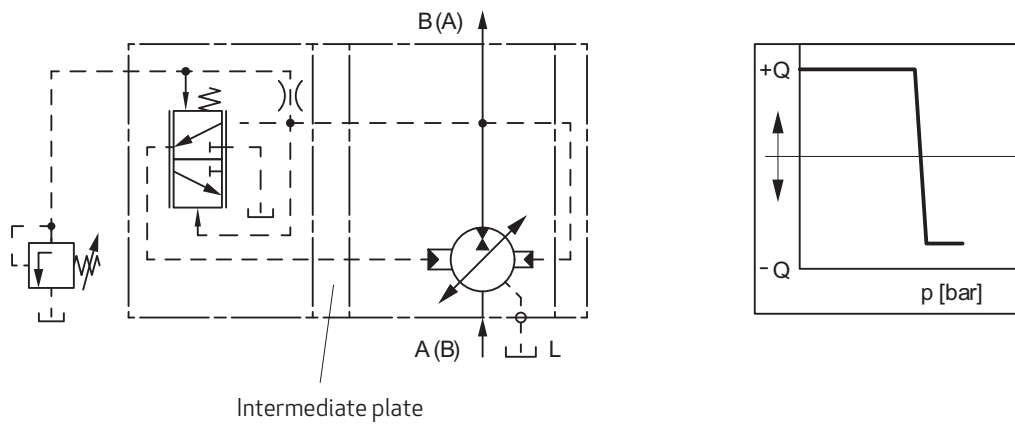

# RADIAL PISTON PUMPS RKP-II

## APPENDIX A – COMPENSATOR OPTIONS

### 4. COMBINED PRESSURE AND FLOW COMPENSATOR („Load sensing“) J1

#### Metering throttle:

Manual adjustable throttle valve or proportional throttle valve.

#### Pressure pilot valve:

Manual adjustable or proportional pressure valve  
 $Q = 0.5 \dots 1.5 \text{ l/min}$ .

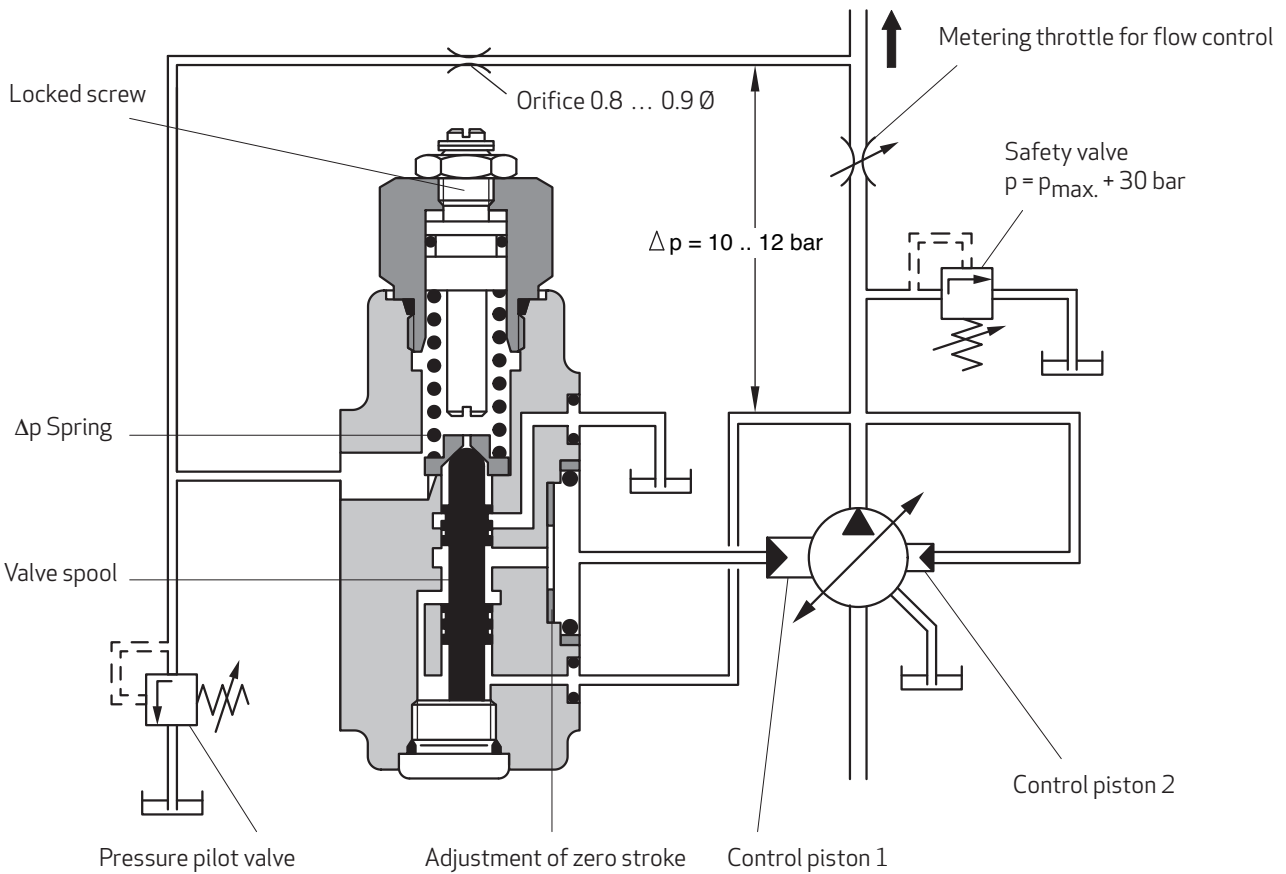
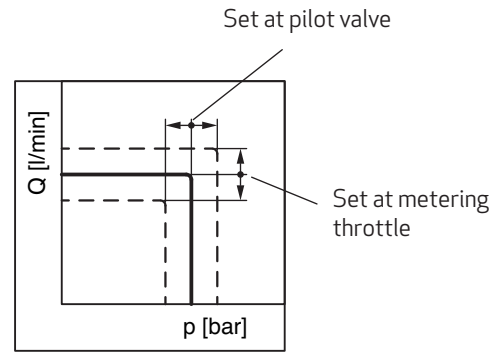
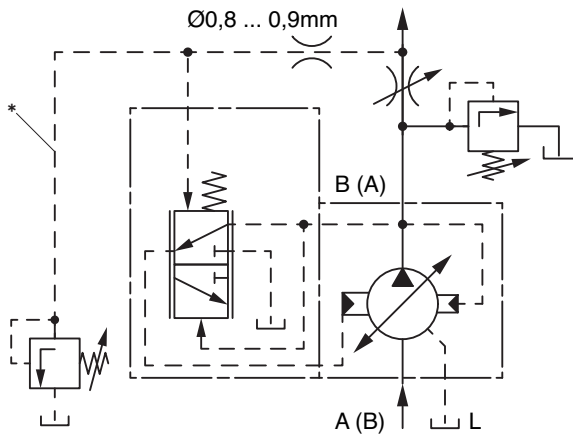

# RADIAL PISTON PUMPS RKP-II

## APPENDIX A – COMPENSATOR OPTIONS

### 5. COMBINED PRESSURE AND FLOW COMPENSATOR WITH P-T CONTROL NOTCH R1

**Metering throttle:**

Manual adjustable throttle valve or proportional throttle valve.

**Pressure pilot valve:**

Manual adjustable or proportional pressure valve  
 $Q = 1 \dots 1.5 \text{ l/min.}$

In multiple pumps feeding in one common line, only **one** compensator with P-T control notch may be installed. This compensator must be set to a higher  $\Delta p$ .

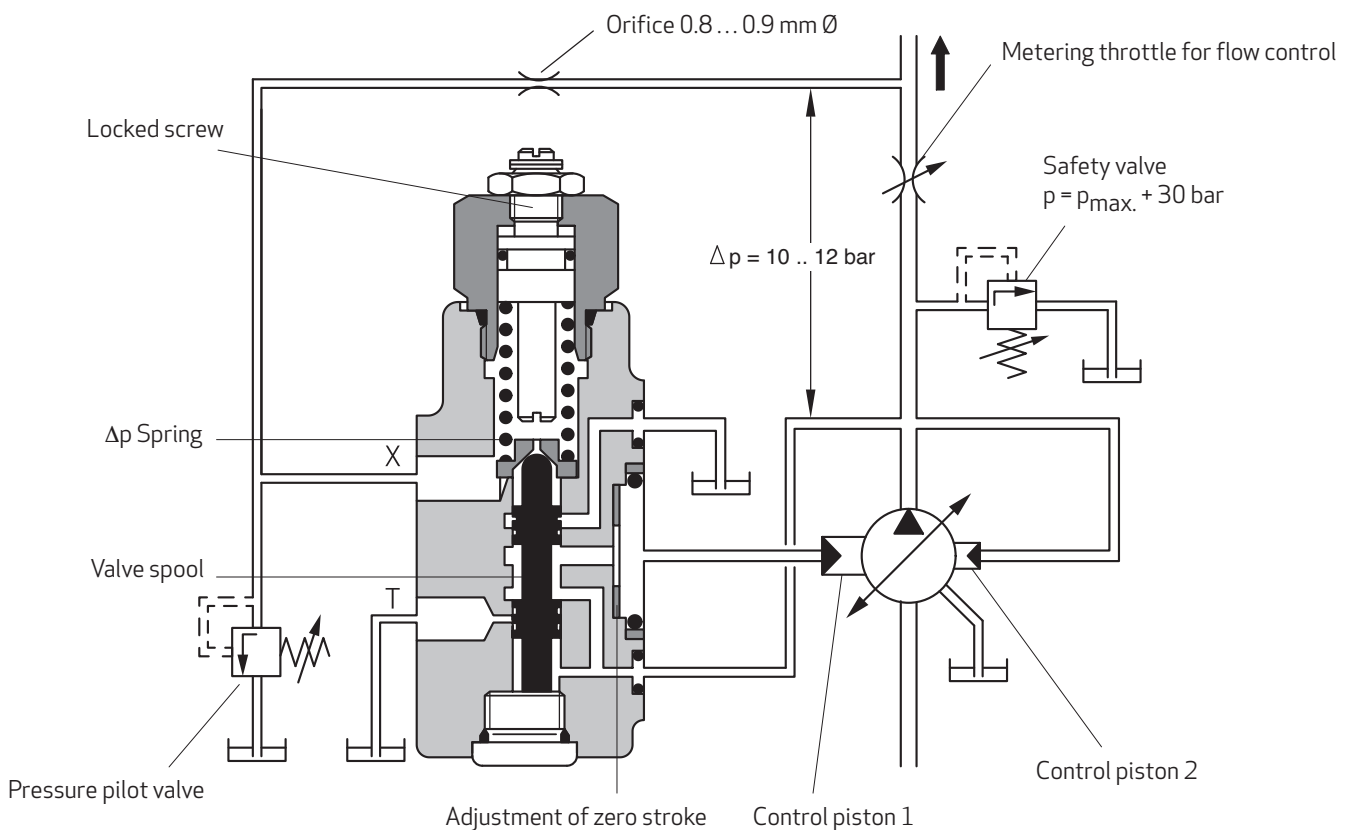
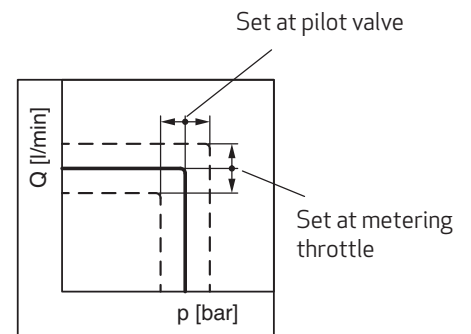
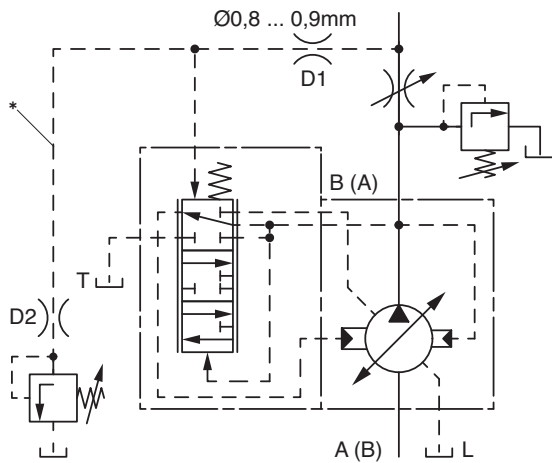

# RADIAL PISTON PUMPS RKP-II

## APPENDIX A – COMPENSATOR OPTIONS

### 6. MECHANICAL STROKE ADJUSTMENT B1

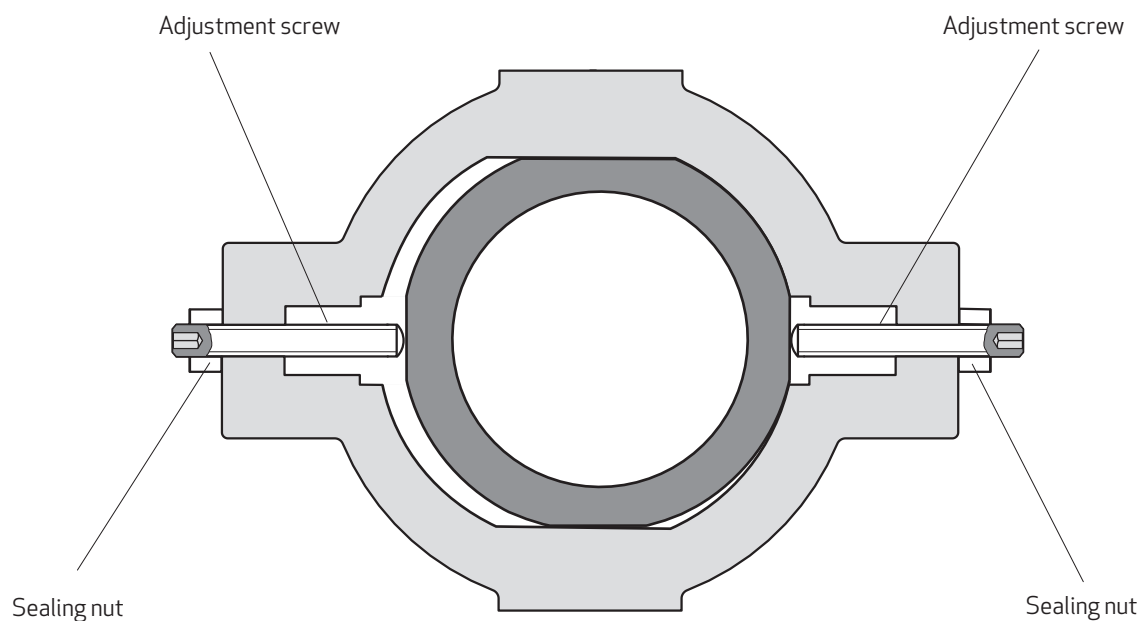
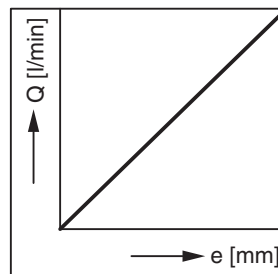
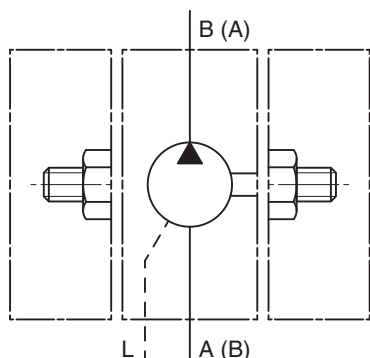

<b>V [cm<sup>3</sup>/rev]</b>	19	32	45	63/80	100	140
<b>ΔV for 1 mm travel of adjusting screw (pitch 1.5 mm/rev)</b>	3.6	5.6	6.5	8.9	11.3	11.5

#### Important

When adjusting for the required delivery, ensure that the stroke ring remains held between the two adjusting screws. When delivered, the pump is set  $V_{max}$ .



# RADIAL PISTON PUMPS RKP-II

## APPENDIX A – COMPENSATOR OPTIONS

### 7. SERVO CONTROL C1

Actuated manually or mechanically by means of a lever.  
The pump displacement is controlled by the position of the lever.

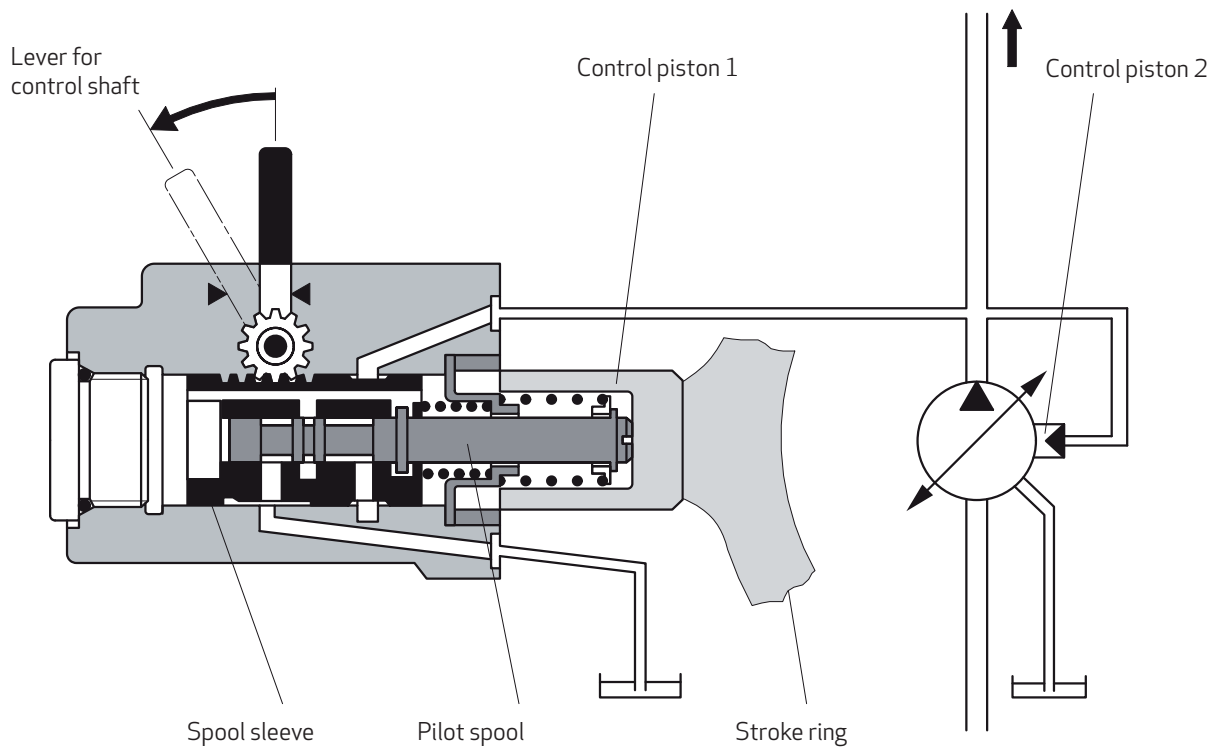
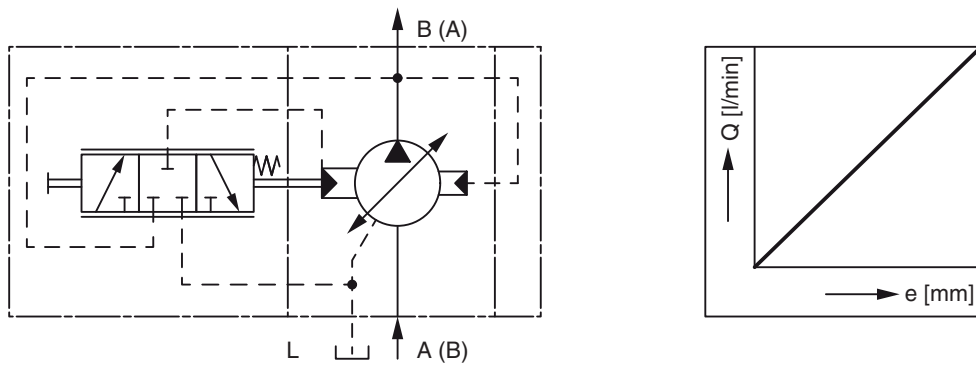

V [cm <sup>3</sup> /rev]	Control torque		
	Neutral position	Final position	max. permissible
19	1.2 Nm	1.7 Nm	8 Nm
32,45	1.2 Nm	1.7 Nm	8 Nm
63,80	1.6 Nm	2.4 Nm	8 Nm
100	1.6 Nm	2.4 Nm	8 Nm

# RADIAL PISTON PUMPS RKP-II

## APPENDIX A - COMPENSATOR OPTIONS

### 8. CONSTANT HORSEPOWER CONTROL S1

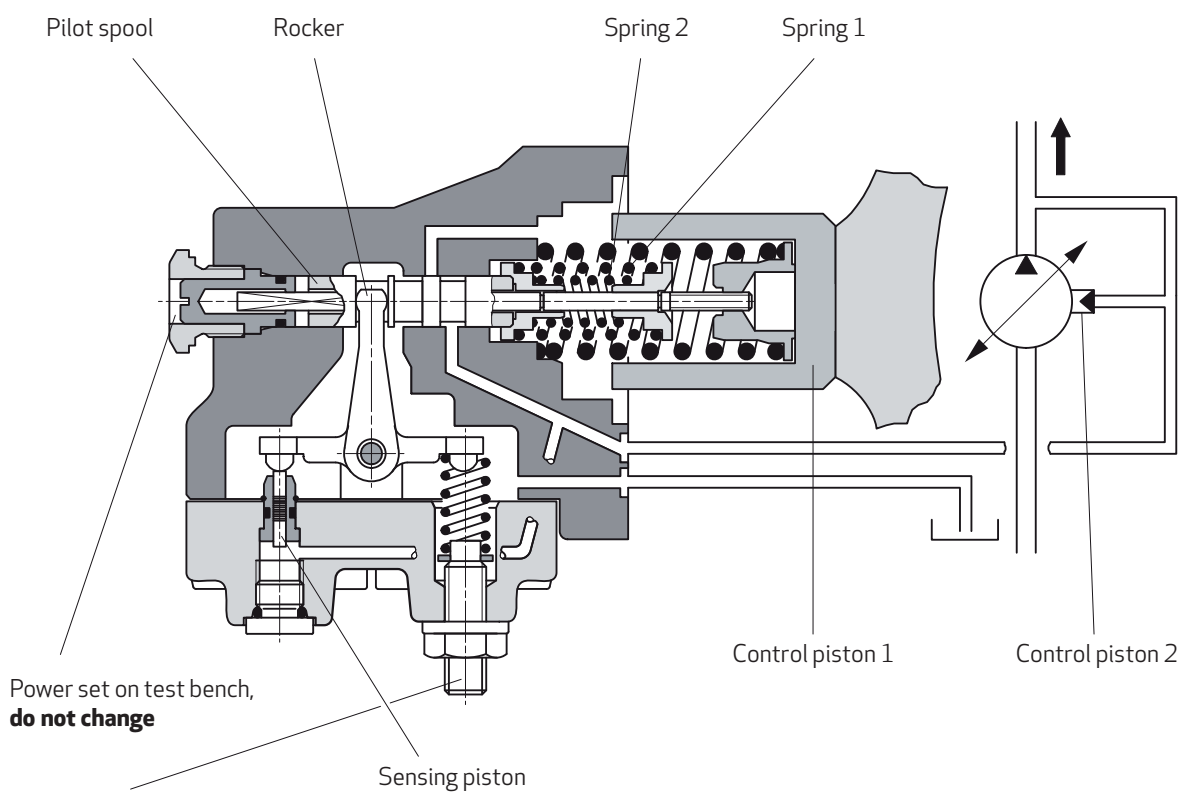
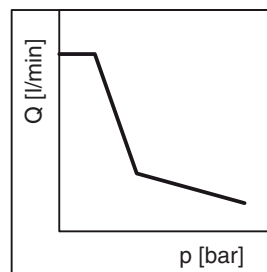
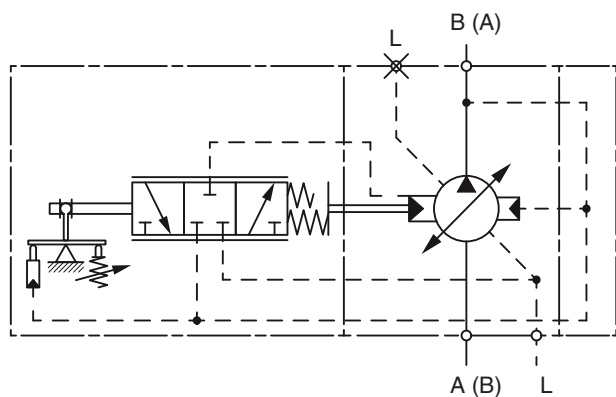

# RADIAL PISTON PUMPS RKP-II

## APPENDIX A – COMPENSATOR OPTIONS

**V = 32 cm<sup>3</sup>/rev**

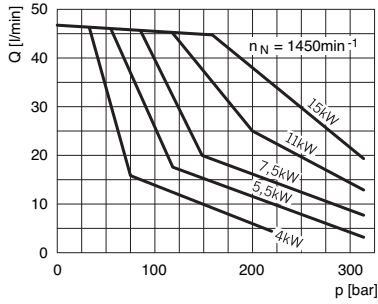

**V = 63 cm<sup>3</sup>/rev**

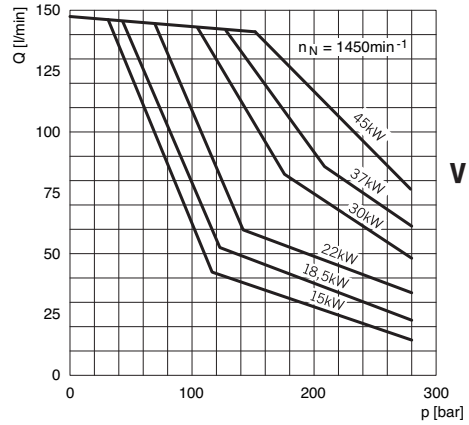
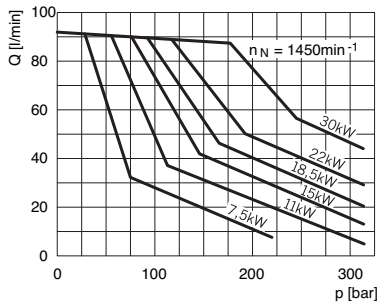

**V = 100 cm<sup>3</sup>/rev**

Approximation of the power hyperbola by 2 springs.

Referenced n = 1450 min<sup>-1</sup>.

For other speeds is valid:

$$P = \frac{P_N \cdot n}{1450}$$

### 9. CONSTANT HORSEPOWER CONTROL WITH REMOTE PRESSURE AND FLOW LIMITER S2

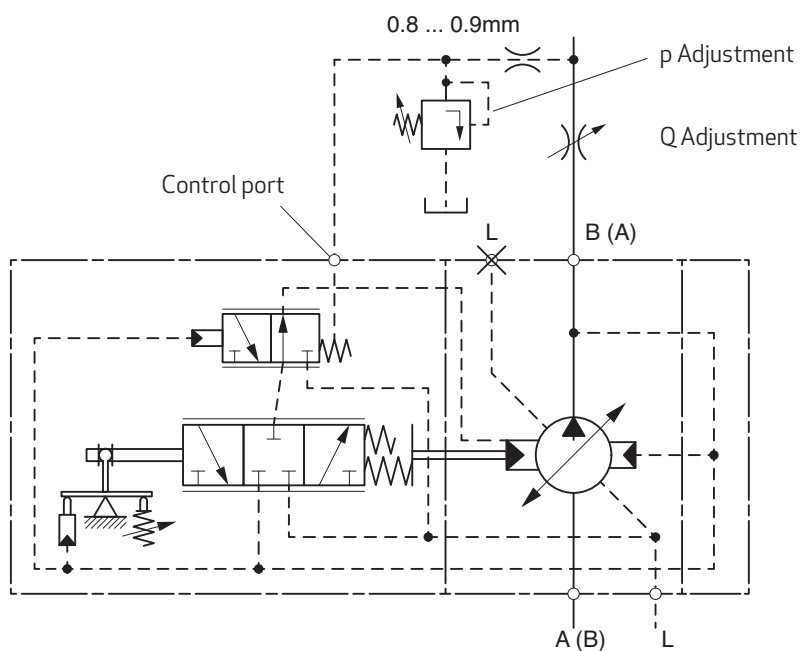

Q Adjustment

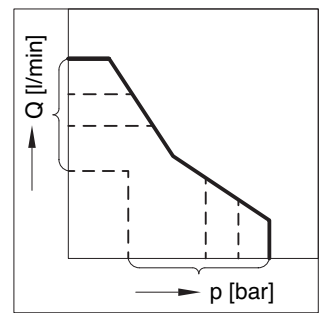

p Adjustment

# RADIAL PISTON PUMPS RKP-II

## APPENDIX A – COMPENSATOR OPTIONS

### 10. ELECTRO-HYDRAULIC CONTROL WITH DIGITAL ON-BOARD ELECTRONICS, D1 TO D8

- Control p/Q: analog 0 – 10 V or using CAN bus
- Pressure controller with 16 selectable parameter sets
- 2 pressure sensors may be connected
- Integrated horse power controller

- Master/slave mode
- Pressure range up to 350 bar constant pressure

For a detailed description and other applications, see catalog for RKP with digital controller (RKP-D).

### RKP WITH DIGITAL CONTROL (RKP-D)

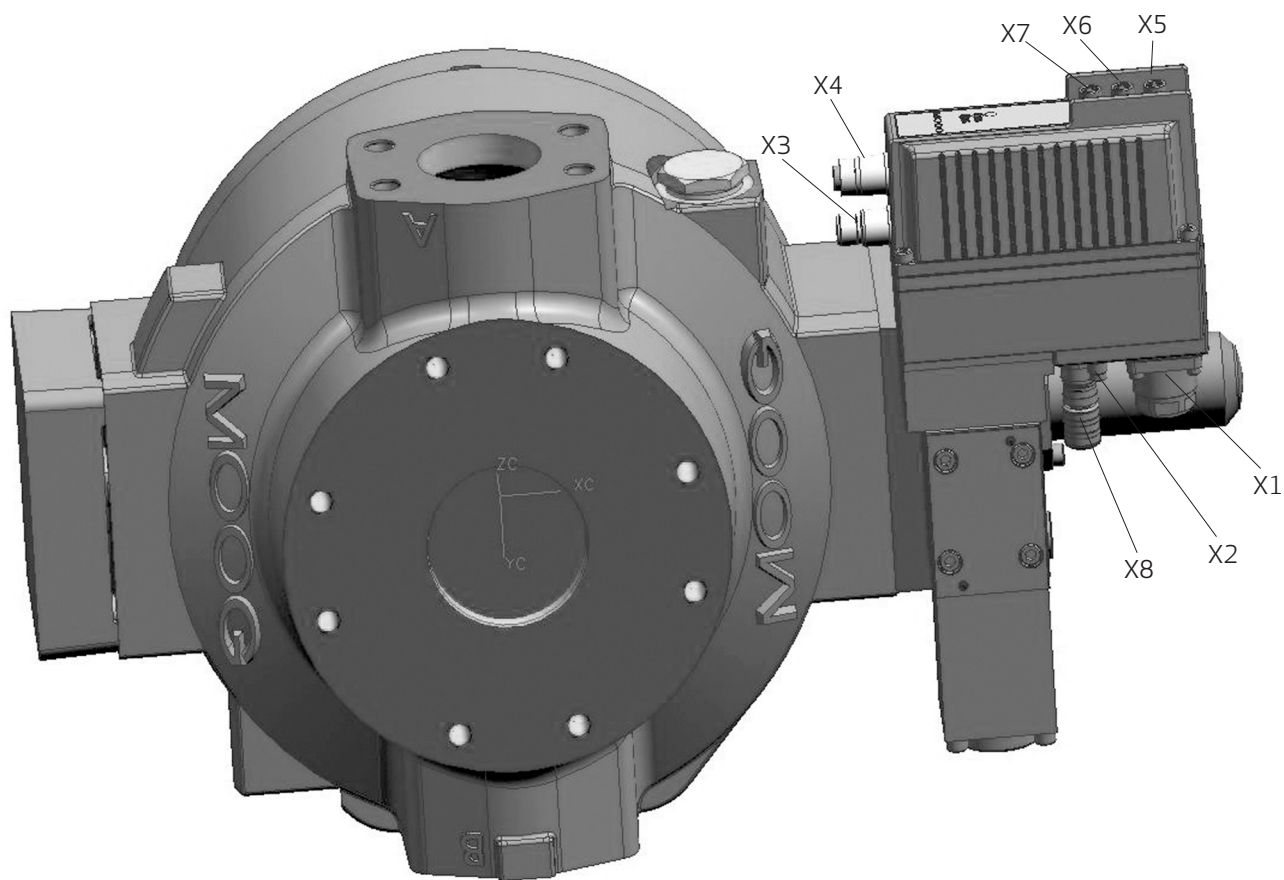

No.	Description	Type
X1	Main connector	11+PE EN 175201 Part 804
X2	LocalCAN (optional) for master/slave mode	M8 x 1 3 pin
X3	CAN	M12x1 5 pin
X4	CAN	M12x1 5 slot
X5	Pressure sensor 2	M8 x 1 4 slot
X6	Pressure sensor 1	M8 x 1 4 slot
X7	Analog selection of parameter sets	M8 x 1 4 slot
X8	LVDT	M12x1 5 slot

Shielding of valve and LVDT: IP67 (with connected and locked receptacles respectively)

# RADIAL PISTON PUMPS RKP-II

## APPENDIX A – COMPENSATOR OPTIONS

### ELECTRO-HYDRAULIC CONTROL WITH DIGITAL ON-BOARD ELECTRONICS, D

#### INTERNAL PRESSURE SUPPLY D1

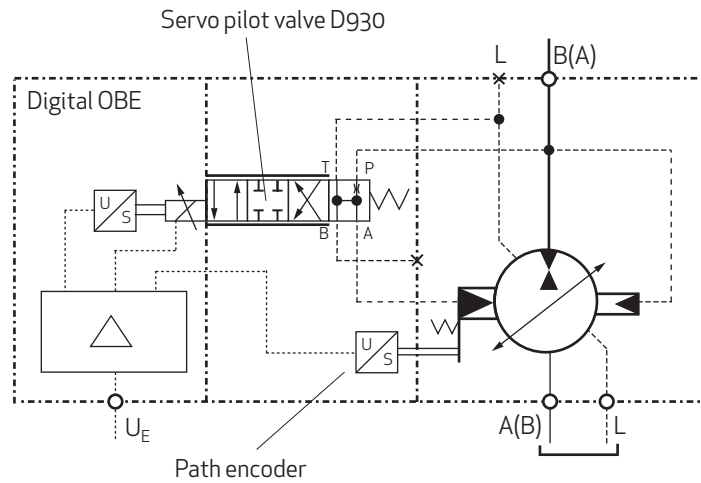

#### EXTERNAL PRESSURE SUPPLY D2

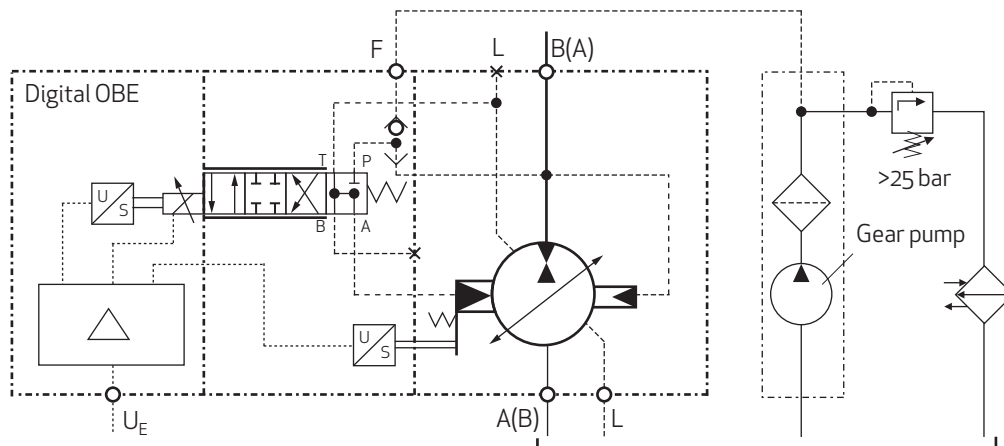

For more information on electro-hydraulically adjustable pumps, see catalog "RKP with digital control" (RKP-D).

# RADIAL PISTON PUMPS RKP-II

## APPENDIX B – TECHNICAL DRAWINGS HOUSINGS RKP-II 63 - 100

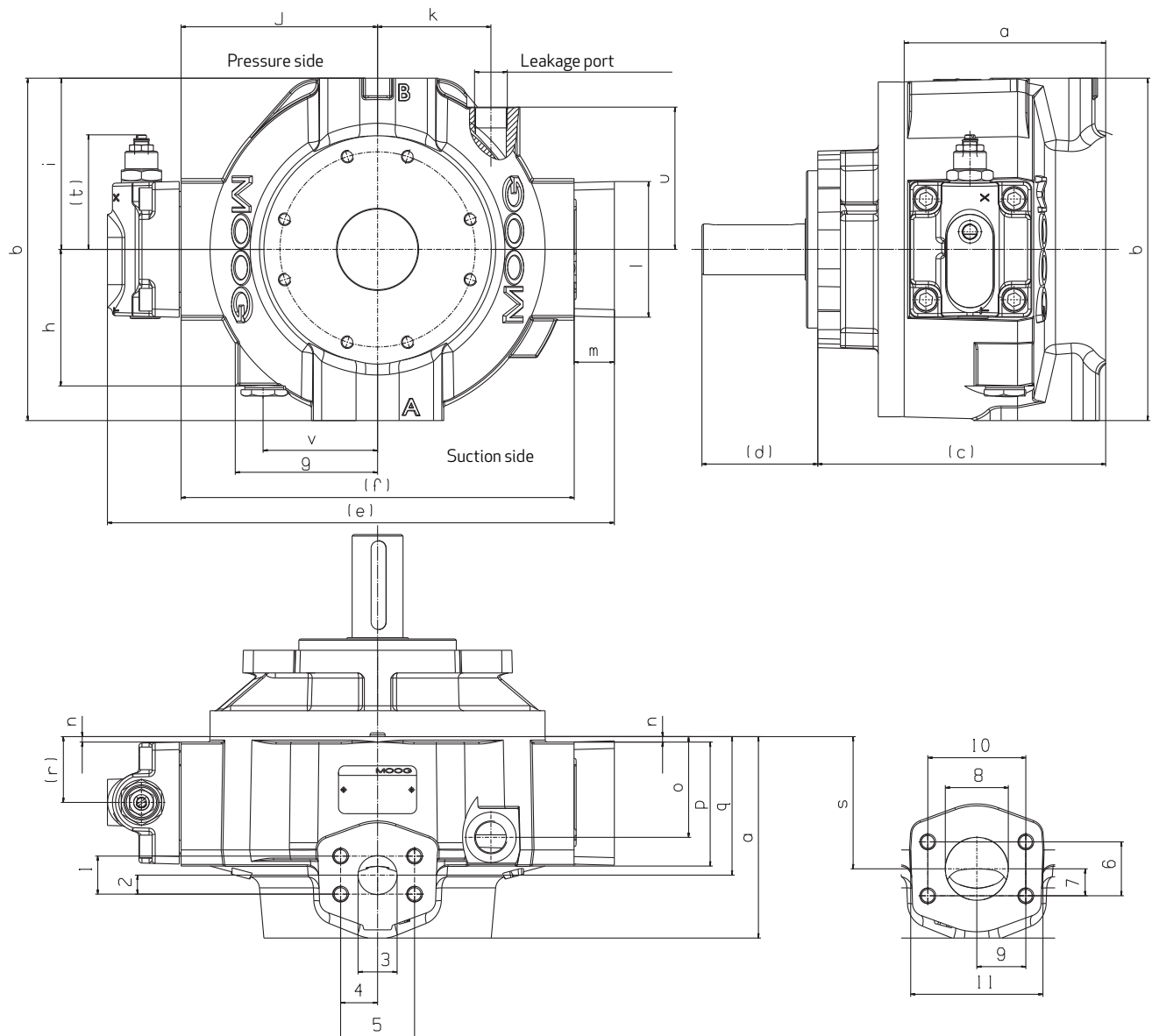

### Caution

Change of rotation not possible.

### MULTIPLE ARRANGEMENT EXAMPLE RKP 63 + 32

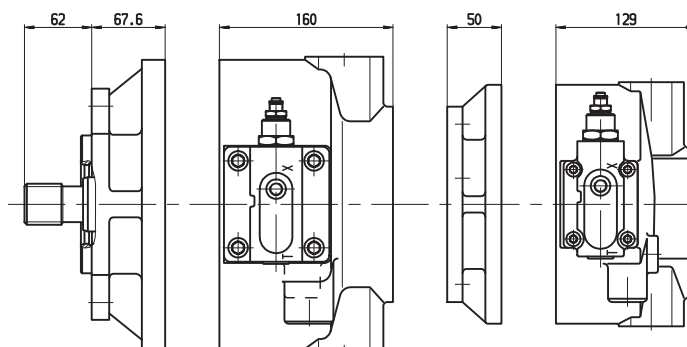

# RADIAL PISTON PUMPS RKP-II

## APPENDIX B – TECHNICAL DRAWINGS HOUSINGS RKP-II 19 - 140

		RKP 19		RKP 32/45		RKP 63/80/100		RKP 140
<b>Length</b>	a	104.00		129.00		160.00		173.50
	b	181.00		225.00		272.00		320.00
<b>Height</b>	(c)	163.10		103.00		228.60		-
	(d)	46.10		78.00		92.00		-
<b>Width</b>	(e)	290.50		319.30		402.50		483.20
	f	212.00		241.00		312.10		398.40
	g	78.00		97.00		113.00		130.00
	h	83.00		87.00		108.00		130.00
	i	90.50		112.50		136.00		160.00
	j	106.00		120.50		156.00		199.20
	k	56.00		84.00		90.00		-
<b>Leakage port</b>		M18 x 1.5 - 13 mm deep		M22 x 1.5 - 14 mm deep		M26 x 1.5 - 16 mm deep		see flange
	l	80.00		81.40		107.70		109.40
	(m)	26.00		26.00		32 (51.7 bei D2, D3, D6)		34.80
	n	1.00		7.50		4.30		5.00
	o	55.00		66.00		80.00		-
	p	70.00		75.50		98.50		114.00
	q	67.00		88.00		110.00		118.00
	(r)	35.00		41.20		52.25		-
	s	67.00		85.00		105.00		118.00
	(t)	max. 103.00		max. 103.00		max. 98.00		-
	u	83.00		87.00		113.00		130.00
	v	56.00		78.00		90.00		-
<b>Pressure port</b>		SAE 3/4" 3000 psi	SAE 3/4" 6000 psi	SAE 1" 3000 psi	SAE 1" 6000 psi	SAE 1 1/4" 3000 psi	SAE 1 1/4" 6000 psi	SAE 1 1/2" 6000 psi
	1	22.20	23.90	26.20	27.80	30.16	31.70	36.50
	2	11.10	11.95	13.10	13.90	15.08	15.85	18.25
	3	19.00	19.00	25.00	25.00	26.00	31.00	38.00
	4	23.81	25.40	26.20	28.60	29.37	33.34	39.65
	5	47.60	50.80	52.40	57.20	58.74	66.68	79.30
	12	M10 16 mm deep	M10 16 mm deep	M10 16 mm deep	M12 21 mm deep	M12 21 mm deep	M14 24 mm tief	M16 25.5 mm deep
<b>Suction port</b>		SAE 3/4" 3000 psi	SAE 3/4" 6000 psi	SAE 1 1/2" - 3000 psi		SAE 2" - 3000 psi		SAE 2 1/2" - 3000 psi
	6	22.20	23.90	35.70		42.80		50.80
	7	11.10	11.95	17.85		21.40		25.40
	8	19.00	19.00	38.00		50.00		62.00
	9	23.81	25.40	34.95		38.90		44.45
	10	47.60	50.80	69.90		77.80		88.90
	11	71.00	71.00	98.00		105.00		117.50
13	M10 16 mm deep	M10 16 mm deep	M12 - 24 mm deep		M12 - 22.5 mm deep		M12 - 22 mm deep	

( ) = as shown with flange A7 and with compensator, F, H, J, R and without  $Q_{max}$  limiting.  
All dimensions in mm; 25.4 mm = 1 inch

# RADIAL PISTON PUMPS RKP-II

## APPENDIX B – TECHNICAL DRAWINGS DRIVE FLANGES RKP-II 19 - 100

### DRIVE FLANGES A7

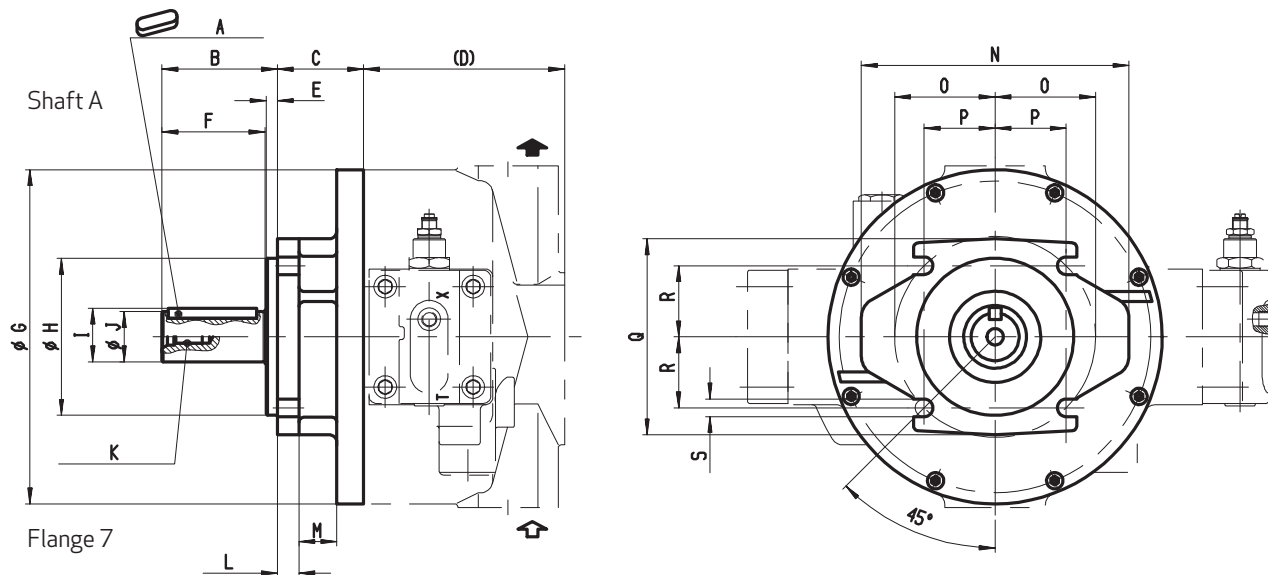

Key to DIN 6885  
 ISO mounting flange to DIN ISO 3019/2  
 (metric dimensions)

	<b>RKP 19</b>	<b>RKP 32/45</b>	<b>RKP 63/80/100</b>
<b>A</b>	A 8 x 7 x 36 DIN 6885	A 10 x 8 x 50 DIN 6885	A 12 x 8 x 70 DIN 6885
<b>B</b>	52.00	68.00	92.00
<b>C</b>	58.10	64.10	68.60
<b>(D)</b>	104.00	129.00	160.00
<b>E</b>	9.00	9.00	9.00
<b>F</b>	42.00	58.00	82.00
<b>G</b>	177.00	220.00	267.00
<b>H</b>	100.00 - 0.054	125.00 - 0.063	125.00 - 0.063
<b>I</b>	27.75	34.75	42.75
<b>J</b>	25.00 + 0.009 / - 0.004	32.00 + 0.018 / + 0.002	40.00 + 0.018 / + 0.002
<b>K</b>	M8 - 22 mm deep	M10 - 22 mm deep	M12 - 32 mm deep
<b>L</b>	11.20	17.20	17.20
<b>M</b>	30.00	30.00	30.00
<b>N</b>	174.00	213.00	213.00
<b>O</b>	62.50	80.00	80.00
<b>P</b>	44.20	56.58	56.58
<b>Q</b>	126.00	156.00	156.00
<b>R</b>	44.20	56.58	56.58
<b>S</b>	11.00	14.00	14.00



# RADIAL PISTON PUMPS RKP-II

## APPENDIX B – TECHNICAL DRAWINGS DRIVE FLANGES RKP-II 19 - 100

### DRIVE FLANGES B7

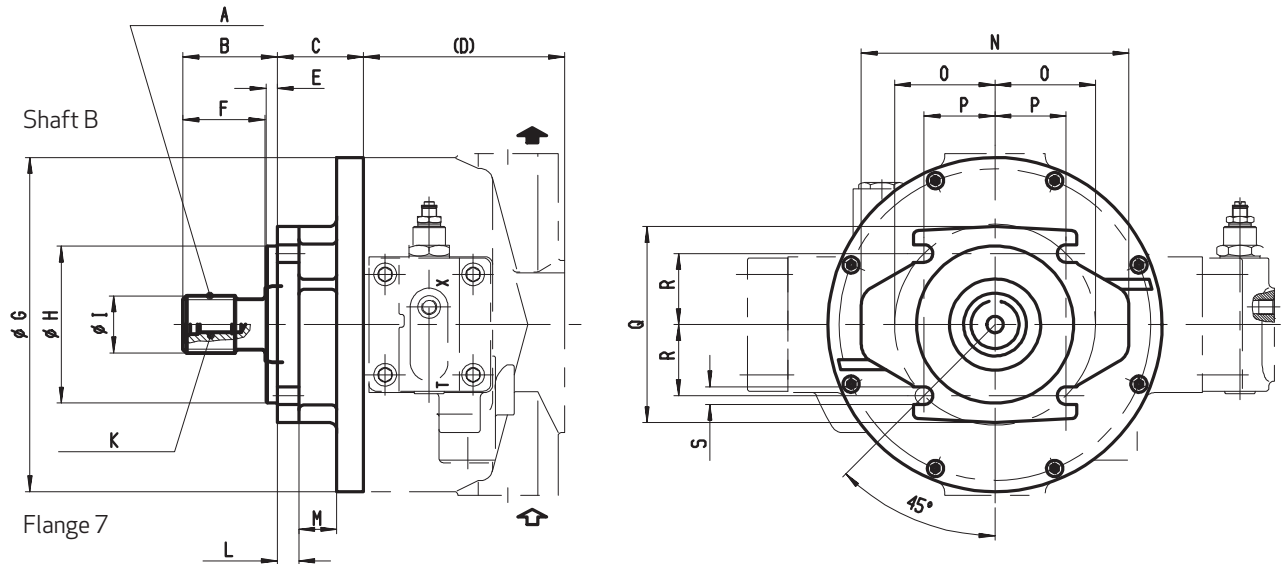

Involute spline to DIN 5480  
 (obligatory with multiple arrangement of RKP and SAE-B)  
 ISO mounting flange to DIN ISO 3019/2  
 (metric dimensions)

	RKP 19	RKP 32/45	RKP 63/80/100
<b>A</b>	W25 x 1.25 x 30 x 18 x 8f	W32 x 2 x 30 x 14 x 8f	W40 x 2 x 30 x 18 x 8f
<b>B</b>	42.00	46.00	54.00
<b>C</b>	58.10	64.10	68.60
<b>(D)</b>	104.00	129.00	160.00
<b>E</b>	9.00	9.00	9.00
<b>F</b>	32.00	36.00	44.00
<b>G</b>	177.00	220.00	267.00
<b>H</b>	100.00 -0.054	125.00 -0.063	125.00 -0.063
<b>I</b>	25.00	32.00	40.00
<b>K</b>	M8 - 22 mm deep	M10 - 22 mm deep	M12 - 32 mm deep
<b>L</b>	11.20	17.20	17.20
<b>M</b>	30.00	30.00	30.00
<b>N</b>	174.00	213.00	213.00
<b>O</b>	62.50	80.00	80.00
<b>P</b>	44.20	56.58	56.58
<b>Q</b>	126.00	156.00	156.00
<b>R</b>	44.20	56.58	56.58
<b>S</b>	11.00	14.00	14.00

# RADIAL PISTON PUMPS RKP-II

## APPENDIX B – TECHNICAL DRAWINGS DRIVE FLANGES RKP-II 19 - 100

### DRIVE FLANGES C3

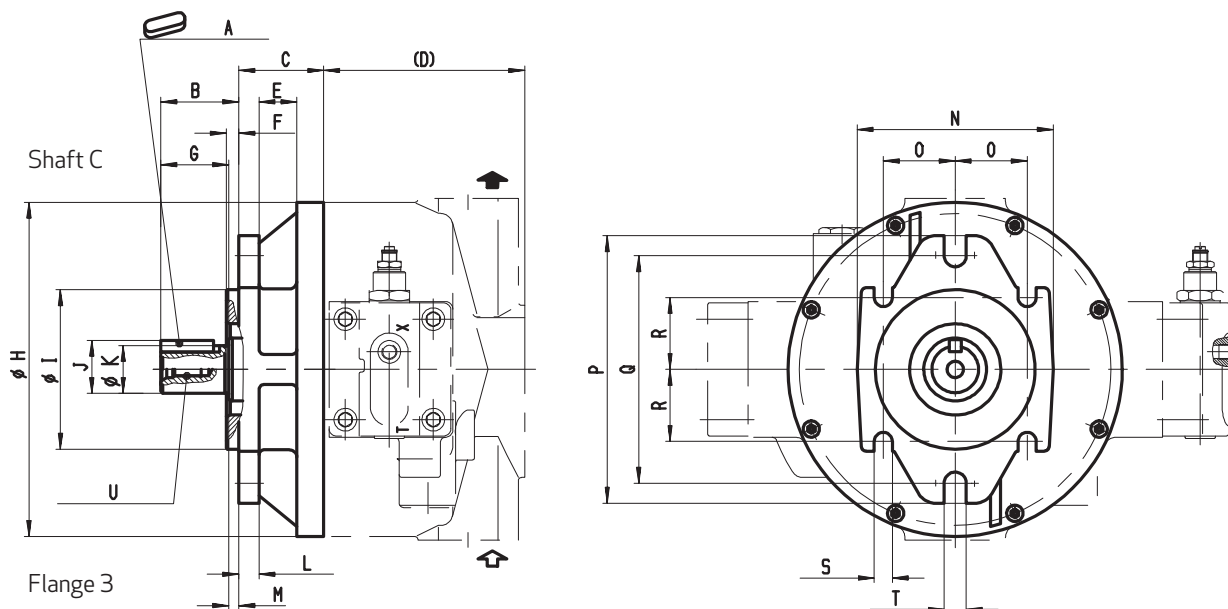

Key to SAE standard  
 SAE mounting flange to DIN ISO 3019/1  
 (imperial dimensions)

	<b>RKP 19</b>	<b>RKP 32/45</b>	<b>RKP 63/80/100</b>
<b>A</b>	6.35 x 6.35 x 25.4	7.94 x 7.94 x 32.0	9.53 x 9.53 x 42.0
<b>B</b>	46.10	57.50	62.00
<b>C</b>	59.10	63.10	67.60
<b>(D)</b>	104.00	129.00	160.00
<b>E</b>	30.00	30.00	30.00
<b>F</b>	8.00	10.00	10.00
<b>G</b>	36.70	46.00	54.00
<b>H</b>	177.00	220.00	267.00
<b>I</b>	101.60 -0.05	127.00 -0.05	127.00 -0.05
<b>J</b>	28.09	35.21	42.27
<b>K</b>	25.40 -0.05	31.75 -0.05	38.10 -0.05
<b>L</b>	12.20	16.20	16.20
<b>M</b>	9.40	11.50	8.00
<b>N</b>	126.00	156.00	156.00
<b>O</b>	45.00	57.25	57.25
<b>P</b>	174.00	213.00	213.00
<b>Q</b>	146.00	181.00	181.00
<b>R</b>	45.00	57.25	57.25
<b>S</b>	14.40	14.40	14.40
<b>T</b>	14.40	17.60	17.60
<b>U</b>	3/8"-16UNC-2B 22 mm deep	3/8"-16UNC-2B 22 mm deep	7/16"-14UNC-2B 32 mm deep

# RADIAL PISTON PUMPS RKP-II

## APPENDIX B – TECHNICAL DRAWINGS DRIVE FLANGES RKP-II 19 - 100

### DRIVE FLANGES D3

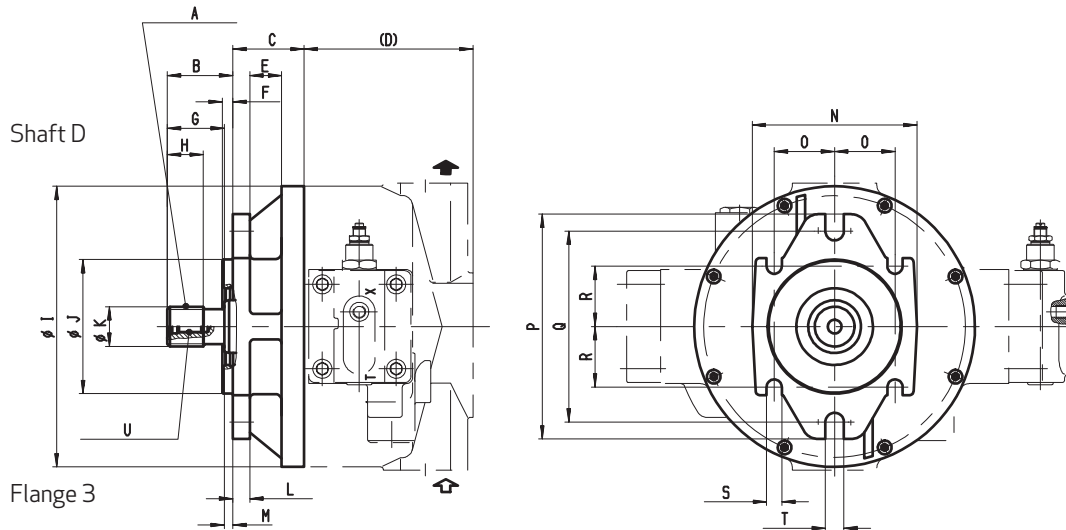

Involute spline to SAE 744 C  
 (obligatory with multiple arrangement of RKP and SAE-B)  
 SAE mounting flange to ISO 3019/1  
 (imperial dimensions)

	<b>RKP 19</b>	<b>RKP 32/45</b>	<b>RKP 63/80/100</b>
<b>A</b>	ANSI B92.1-1970 Class 5 30PA. 15T, 16/32DP Flat root side fit	ANSI B92.1-1970 Class 5 30PA. 14T, 12/24DP Flat root side fit	ANSI B92.1-1970 Class 5 30PA. 17T, 12/24DP Flat root side fit
<b>B</b>	46.00	56.00	62.00
<b>C</b>	59.10	63.10	67.60
<b>(D)</b>	104.00	129.00	160.00
<b>E</b>	30.00	30.00	30.00
<b>F</b>	8.00	10.00	10.00
<b>G</b>	38.00	48.00	54.00
<b>H</b>	23.00	29.00	34.00
<b>I</b>	177.00	220.00	267.00
<b>J</b>	101.60	127.00	127.00
<b>K</b>	25.20	31.50	37.70
<b>L</b>	12.20	16.20	16.20
<b>M</b>	8.00	8.00	8.00
<b>N</b>	126.00	156.00	156.00
<b>O</b>	45.00	57.25	57.25
<b>P</b>	174.00	213.00	213.00
<b>Q</b>	146.00	181.00	181.00
<b>R</b>	45.00	57.25	57.25
<b>S</b>	14.40	14.40	14.40
<b>T</b>	14.40	17.60	17.60
<b>U</b>	3/8"-16UNC-2B 22 mm deep	3/8"-16UNC-2B 22 mm deep	7/16"-14UNC-2B 32 mm deep

# RADIAL PISTON PUMPS RKP-II

## APPENDIX B – TECHNICAL DRAWINGS DRIVE FLANGES RKP-II 19 - 100

### FLANGES A1

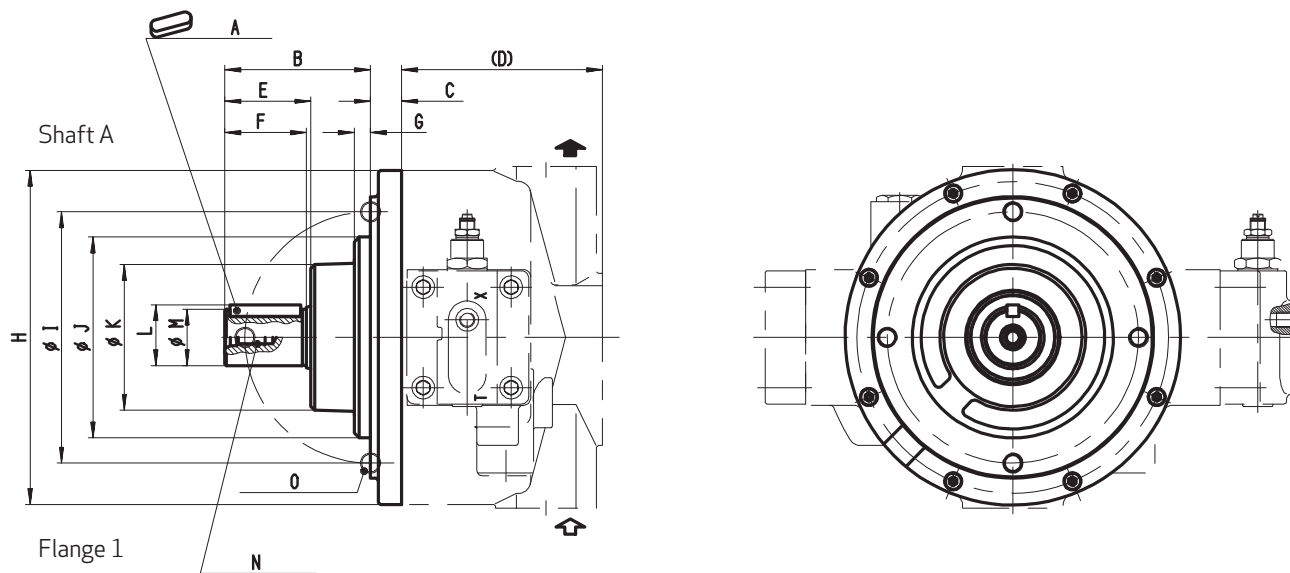

Key to DIN 6885  
Metric round flange

	RKP 19	RKP 32/45	RKP 63/80/100
<b>A</b>	A 8 x 7 x 32 DIN 6885	A 10 x 8 x 45 DIN 6885	A 14 x 9 x 56 DIN 6885
<b>B</b>	70.70	94.50	116.00
<b>C</b>	17.10	18.10	24.70
<b>(D)</b>	104.00	129.00	160.00
<b>E</b>	42.90	57.50	68.50
<b>F</b>	41.20	55.00	65.00
<b>G</b>	11.40	11.00	13.00
<b>H</b>	177.00	220.00	267.00
<b>I</b>	125.00 ±0.15	160.00 ±0.15	200.00 ±0.15
<b>J</b>	100.00 -0.036/-0.09	125.00 -0.043/-0.106	160.00 -0.043/-0.106
<b>K</b>	79.00	101.00	116.00
<b>L</b>	30.75	37.85	48.40
<b>M</b>	28.00 -0.013	35.00 -0.016	45.00 -0.016
<b>N</b>	M10 - 22 mm deep	M10 - 22 mm deep	M12 - 32 mm deep
<b>O</b>	M10 - 15 mm deep	M12 - 16 mm deep	M16 - 23 mm deep

# RADIAL PISTON PUMPS RKP-II

## APPENDIX B – TECHNICAL DRAWINGS DRIVE FLANGES RKP-II 19 - 100

### FLANGES B1

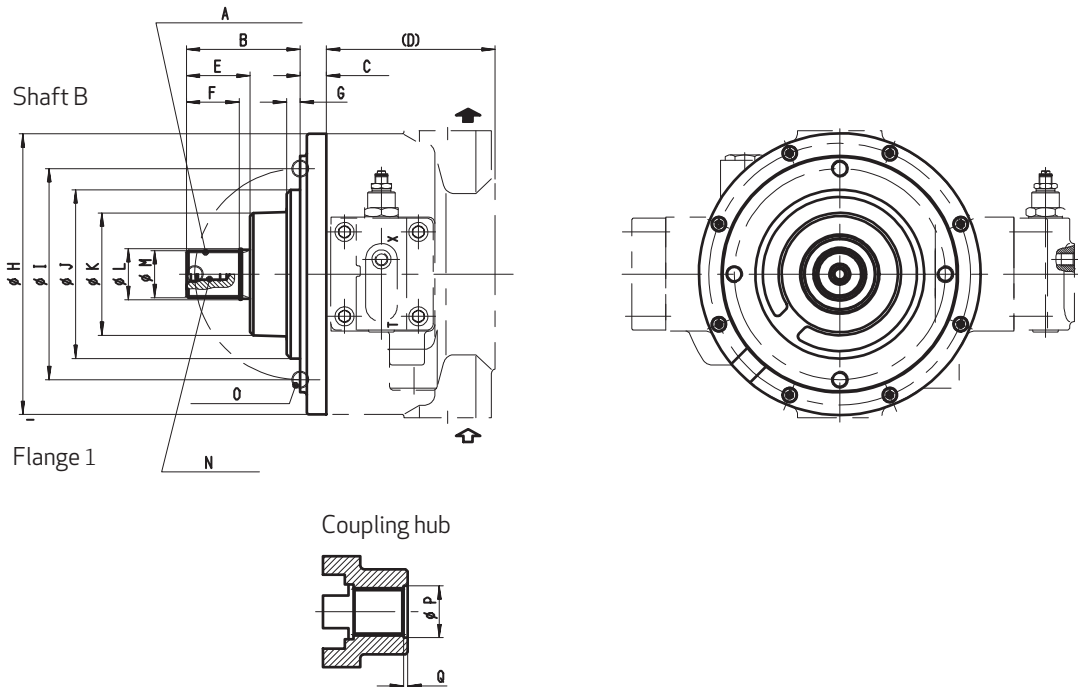

Involute spline to DIN 5482 (for B1)  
 (obligatory with multiple arrangement of RKP and SAE-B)  
 Metric round flange

	RKP 19	RKP 32/45	RKP 63/80/100
<b>A</b>	DIN 5482 B 28 x 25 e9	DIN 5482 B 35 x 31 e9	DIN 5482 B 45 x 41 e9
<b>B</b>	72.60	95.50	107.90
<b>C</b>	17.10	18.10	24.70
<b>(D)</b>	104.00	129.00	160.00
<b>E</b>	44.80	58.50	60.40
<b>F</b>	30.00	40.00	50.00
<b>G</b>	11.40	11.00	13.00
<b>H</b>	177.00	220.00	267.00
<b>I</b>	125.00 ± 0.15	160.00 ± 0.15	200.00 ± 0.15
<b>J</b>	100.00 -0.090 / -0.036	125.00 -0.043 / -0.106	160.00 -0.043 / -0.106
<b>K</b>	79.00	101.00	116.00
<b>L</b>	30.80 ± 0.25	38.50 ± 0.25	48.45 ± 0.25
<b>M</b>	27.50 -0.130	34.44 -0.160	44.50 -0.160
<b>N</b>	M10 - 22 mm deep	M10 - 22 mm deep	M12 - 32 mm deep
<b>O</b>	M10 - 15 mm deep	M12 - 15 mm deep	M16 - 23 mm deep
<b>P</b>	31.30 + 0.20	39.00 + 0.20	49.00 + 0.20
<b>Q</b>	4.00	4.00	4.00

# RADIAL PISTON PUMPS RKP-II

## APPENDIX B – TECHNICAL DRAWINGS DRIVE FLANGES RKP-II 19 - 100

### INTERMEDIATE FLANGE XX (RKP-RKP)

#### RKP 19/32/45

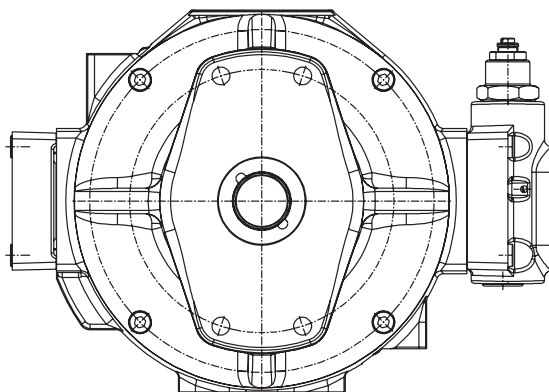
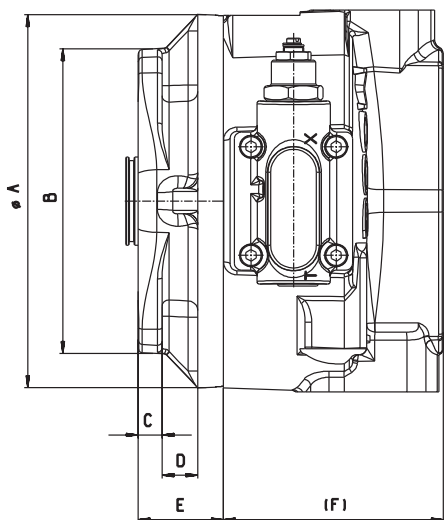

#### RKP 63/80/100

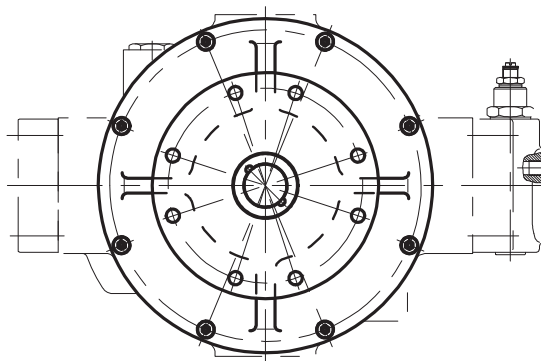
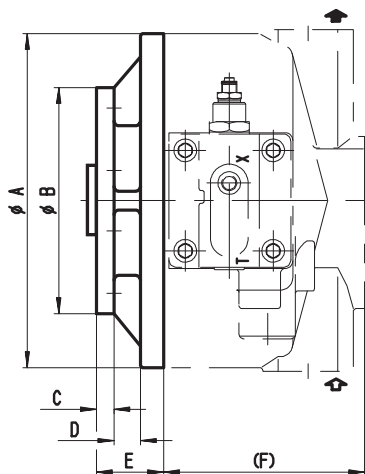

	RKP 19	RKP 32/45	RKP 63/80/100
<b>A</b>	177.00	220.00	266.00
<b>B</b>	180.00	180.00	180.00
<b>C</b>	14.00	14.00	14.00
<b>D</b>	23.50	21.00	21.00
<b>E</b>	50.00	50.00	53.50
<b>(F)</b>	104.00	129.00	160.00

# RADIAL PISTON PUMPS RKP-II

## APPENDIX B – TECHNICAL DRAWINGS COMPENSATORS RKP-II 19 - 100

- ADJUSTABLE PRESSURE COMPENSATOR F1, F2
- REMOTE PRESSURE COMPENSATOR H1
- COMBINED PRESSURE AND FLOW COMPENSATOR J1, J2
- PRESSURE AND FLOW CONTROL WITH P-T CONTROL NOTCH R1

### RKP 19/32/45

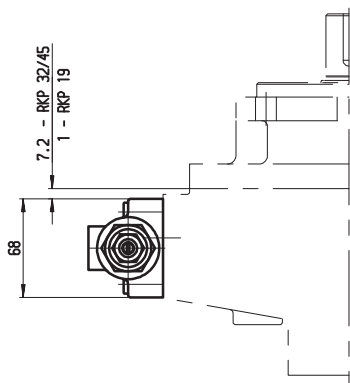
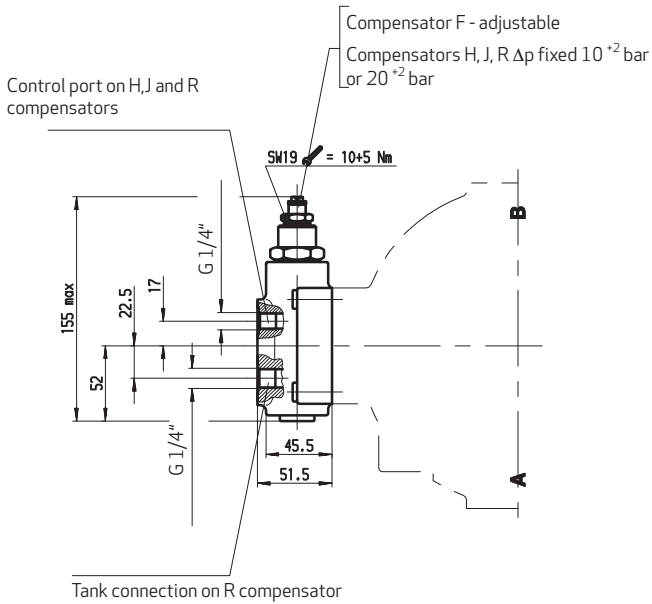

### RKP 63/80/100

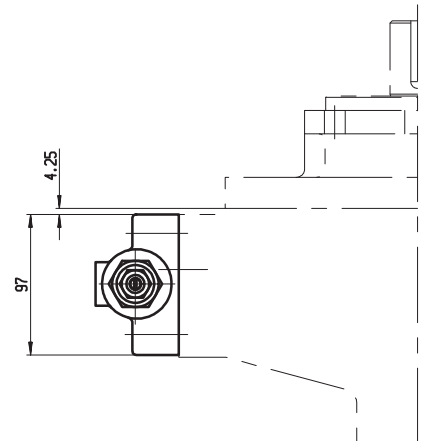
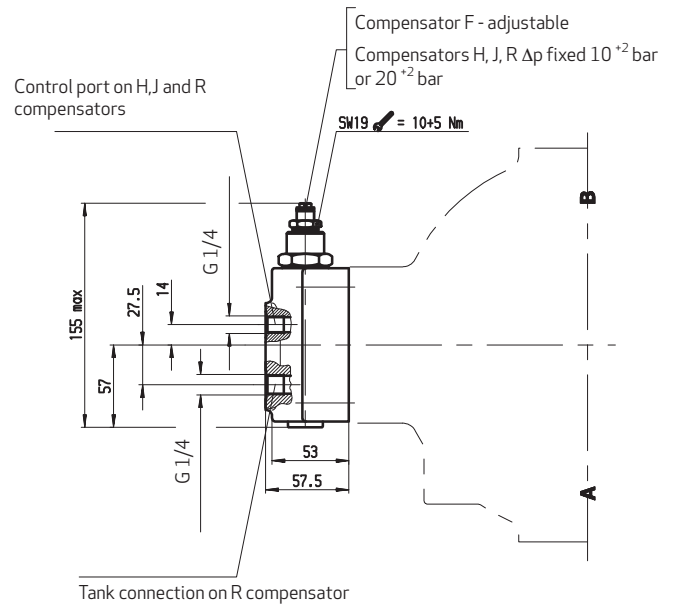

# RADIAL PISTON PUMPS RKP-II

## APPENDIX B – TECHNICAL DRAWINGS COMPENSATORS RKP-II 19 - 100

### ADJUSTABLE PRESSURE COMPENSATOR F1, F2

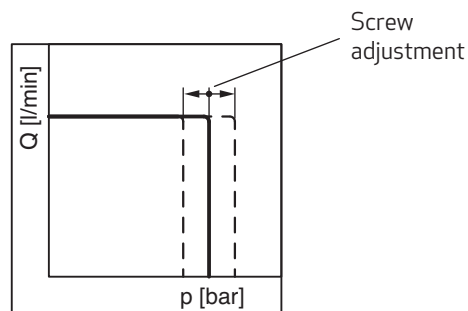
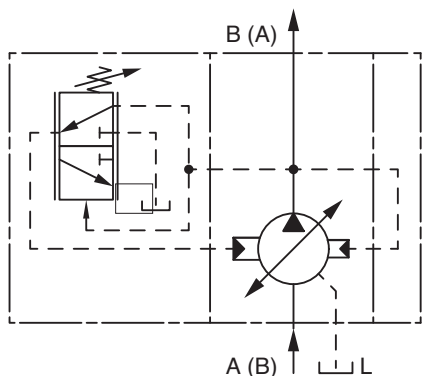

### REMOTE PRESSURE COMPENSATOR H1

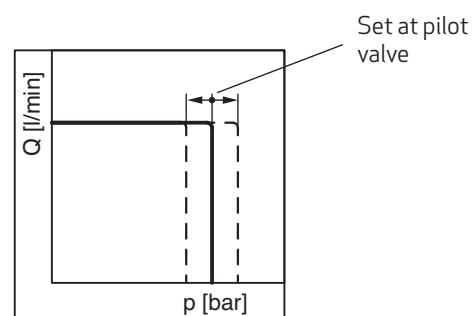
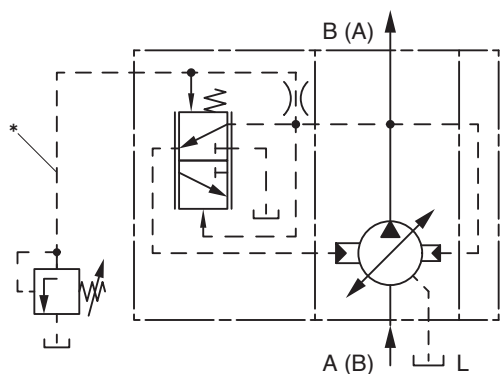

### COMBINED PRESSURE AND FLOW COMPENSATOR J1, J2

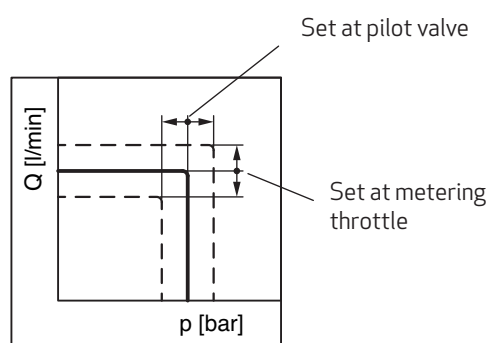
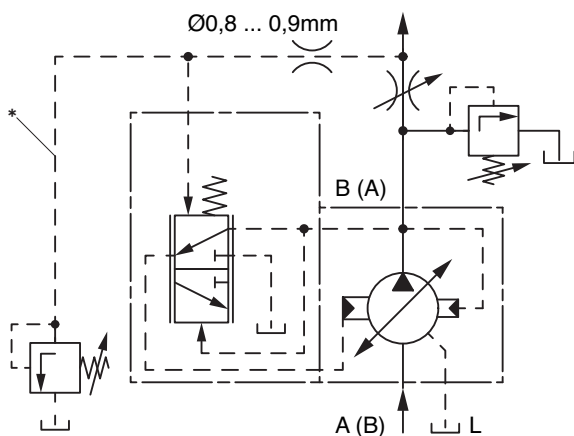

When high dynamics are required for flow control, adjust orifice and control line accordingly.

\* Hose recommendation for control line

<b>RKP 19</b>	DN 6
<b>RKP 32, RKP 45</b>	DN 8
<b>RKP 63, RKP 80, RKP 100</b>	DN 10
<b>l = 800 mm</b>	



# RADIAL PISTON PUMPS RKP-II

## APPENDIX B – TECHNICAL DRAWINGS COMPENSATORS RKP-II 19 - 100

### COMBINED PRESSURE AND FLOW COMPENSATOR "LOAD SENSING" WITH P-T CONTROL NOTCH R1

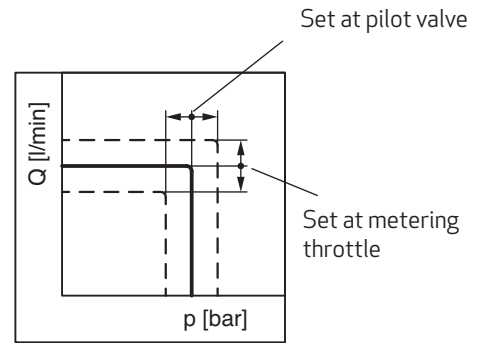
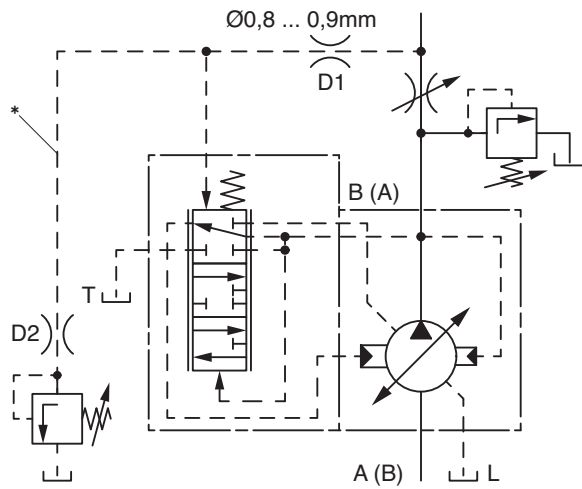

\* Hose recommendation for control line

		D1	D2
RKP 19 ... 45	DN 6	0.9	1.2
RKP 63 ... 100	DN 8	0.9	1.2
l = 800 mm			

#### Notes on multiple pump circuits

In the case of multiple pumps, which deliver into one circuit, the P-T control notch may only be activated for the compensator of the first pump by connecting the T-connection to the tank. The T-connection of the compensators of add-on pumps must be sealed off.

#### Caution!

The tank line of the compensator must not be combined with the drain line of the pump

# RADIAL PISTON PUMPS RKP-II

## APPENDIX B – TECHNICAL DRAWINGS COMPENSATORS RKP-II 19 - 100

### ADJUSTABLE PRESSURE COMPENSATOR, LOCKABLE KNOB WITH H KEY G1 , G2

RKP 19/32/45

RKP 63/80/100

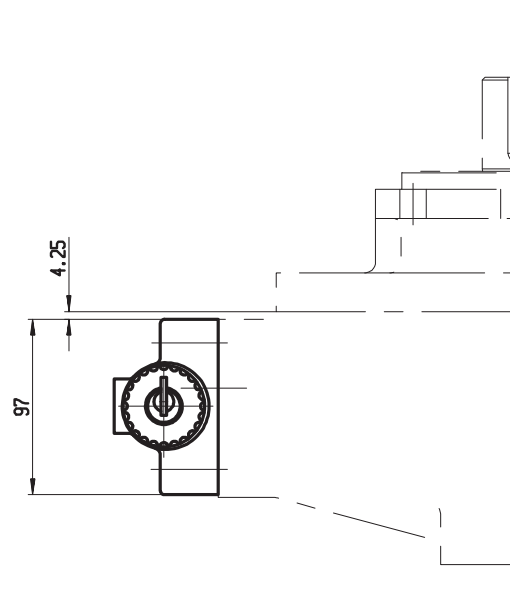
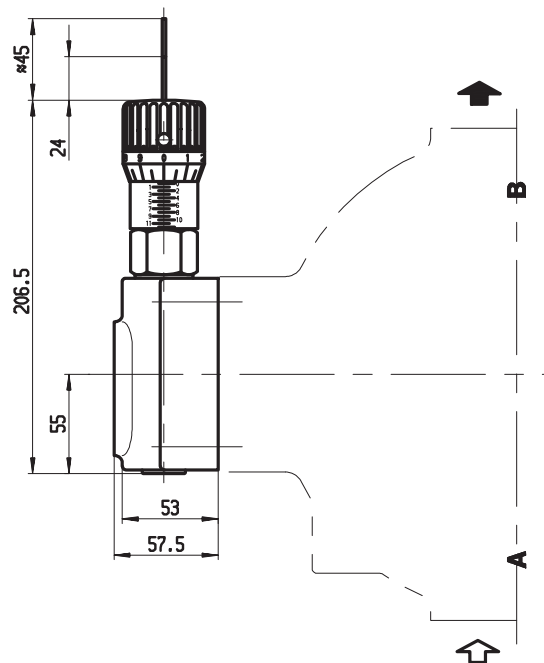
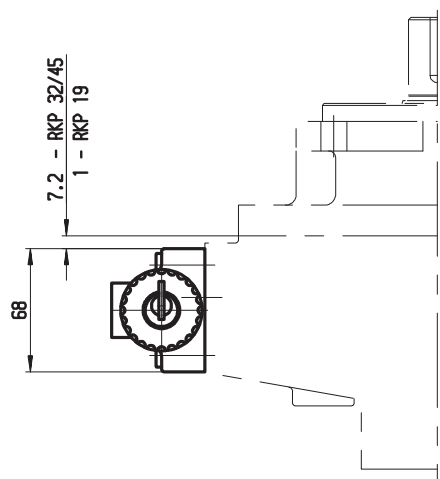
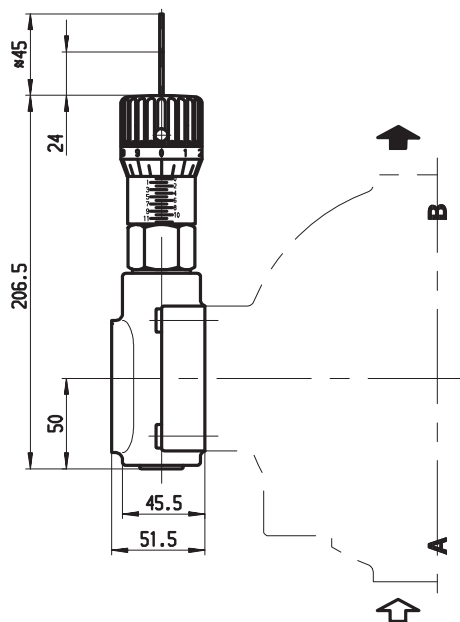

# RADIAL PISTON PUMPS RKP-II

## APPENDIX B – TECHNICAL DRAWINGS COMPENSATORS RKP-II 19 - 100

### ELECTRO-HYDRAULIC CONTROL WITH DIGITAL ON-BOARD ELECTRONICS D1 TO D8

#### RKP 19/32/45

#### RKP 63/80/100

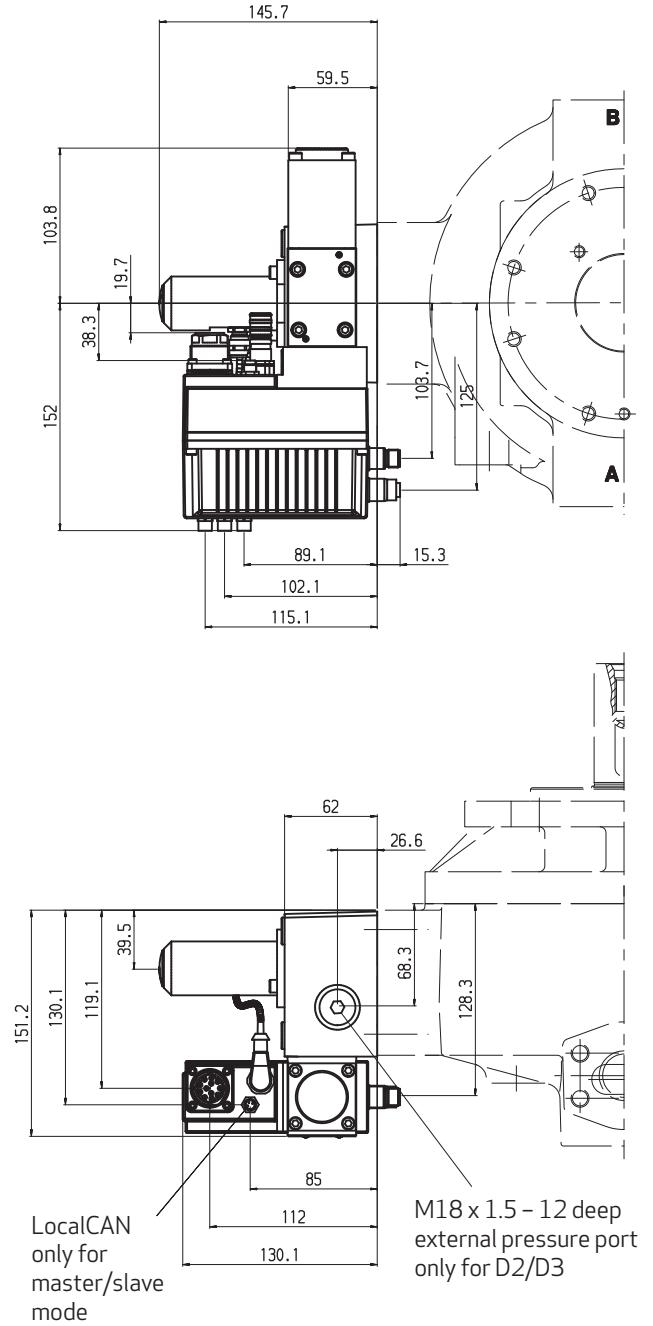
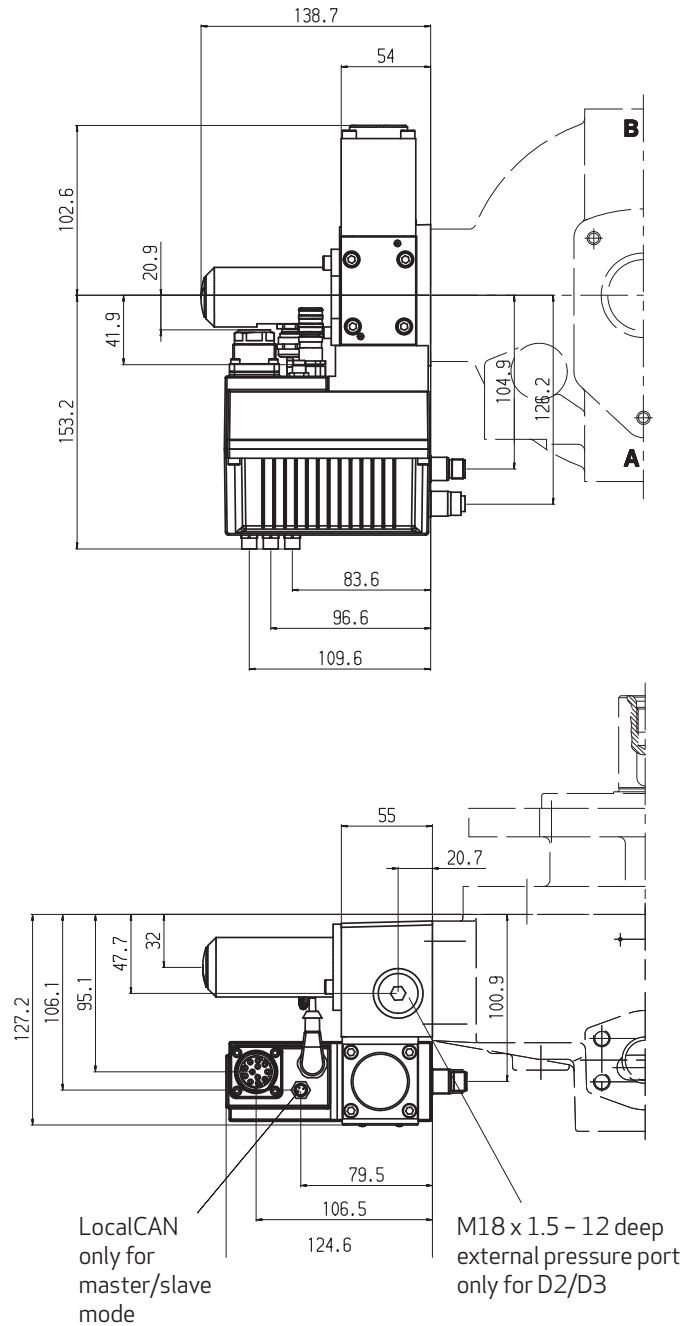

# RADIAL PISTON PUMPS RKP-II

## APPENDIX B – TECHNICAL DRAWINGS COMPENSATORS RKP-II 19 - 100

### CONSTANT HORSEPOWER CONTROL S1

#### RKP 32

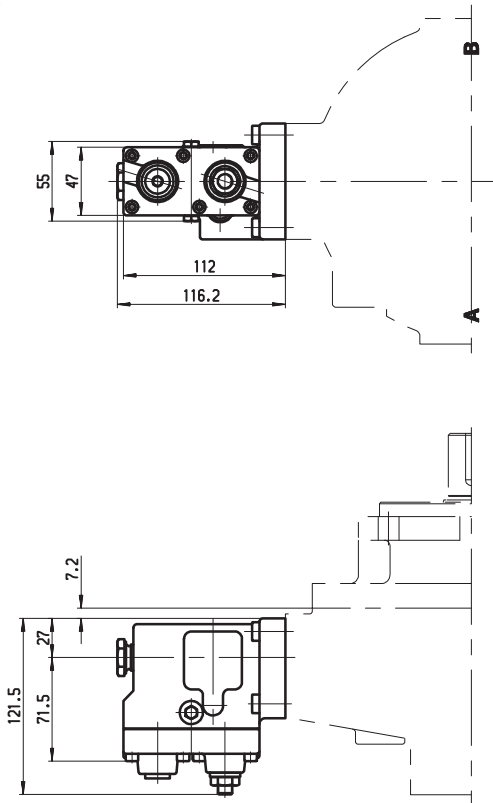

#### RKP 63/100

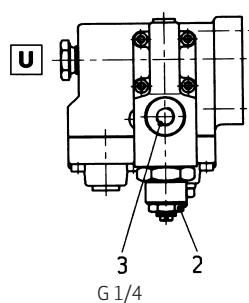
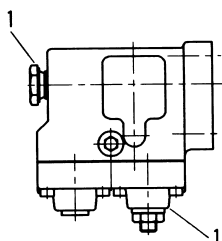
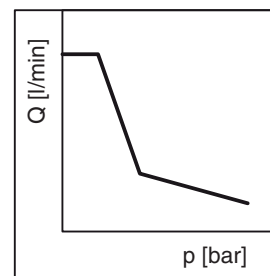
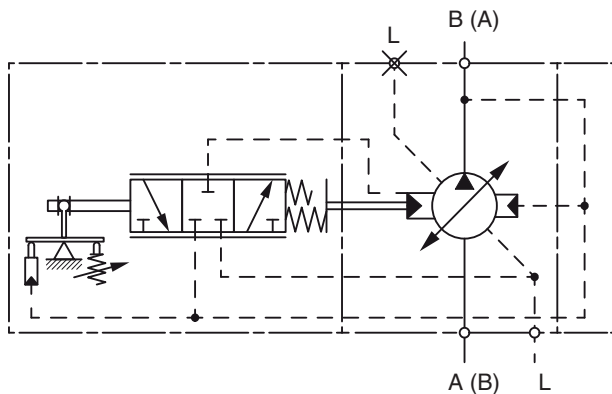
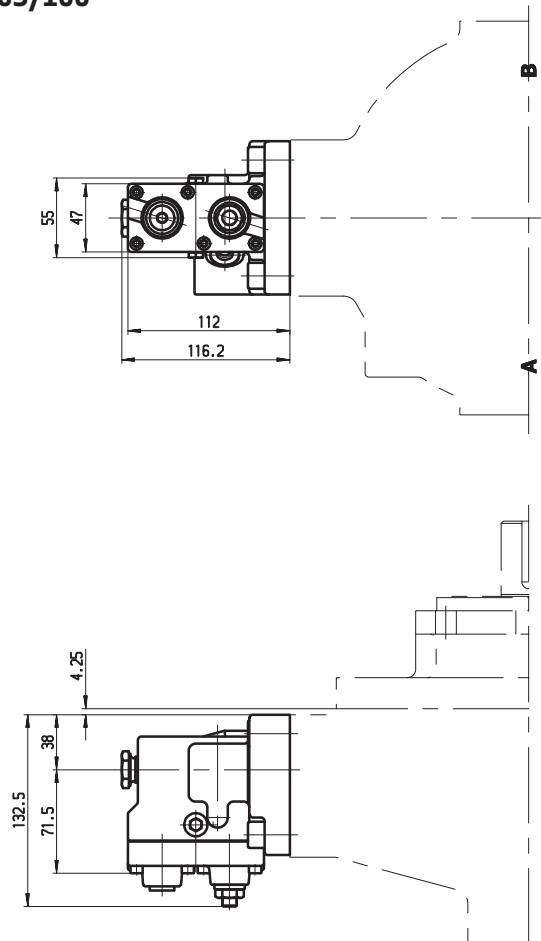

- 1 Horsepower adjustment  
(set at factory, do not change)
  - 2 Set at factory ( $\Delta p = 10^{-2}$  bar)
  - 3 Control port
- For control line information, see H and J controller details

# RADIAL PISTON PUMPS RKP-II

## APPENDIX B – TECHNICAL DRAWINGS COMPENSATORS RKP-II 19 - 100

### CONSTANT HORSEPOWER CONTROL WITH REMOTE PRESSURE AND FLOW CONTROL S2

RKP 32

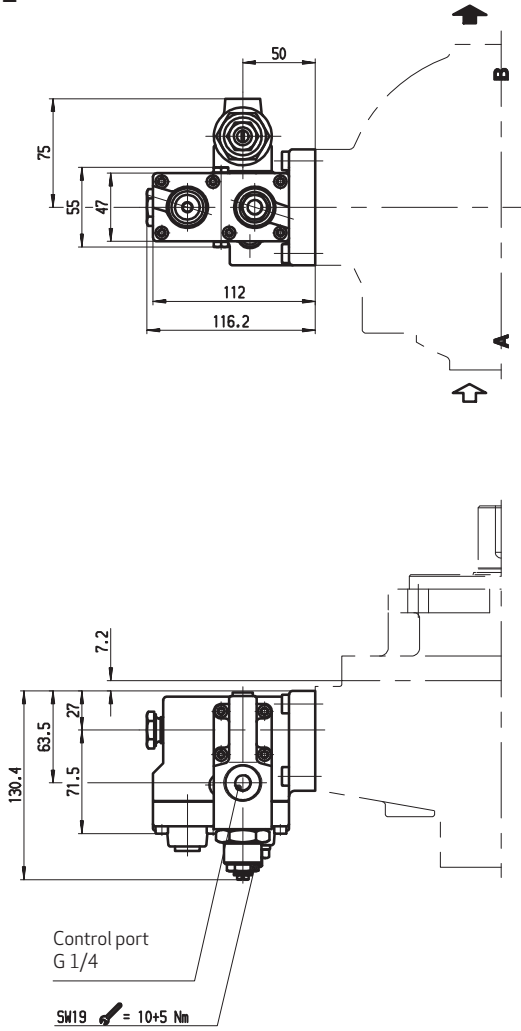

RKP 63/100

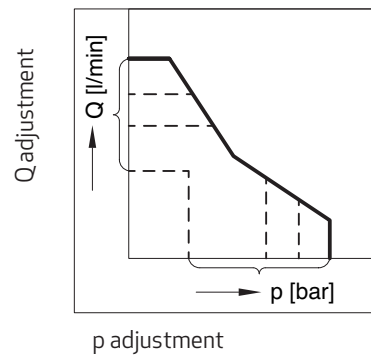
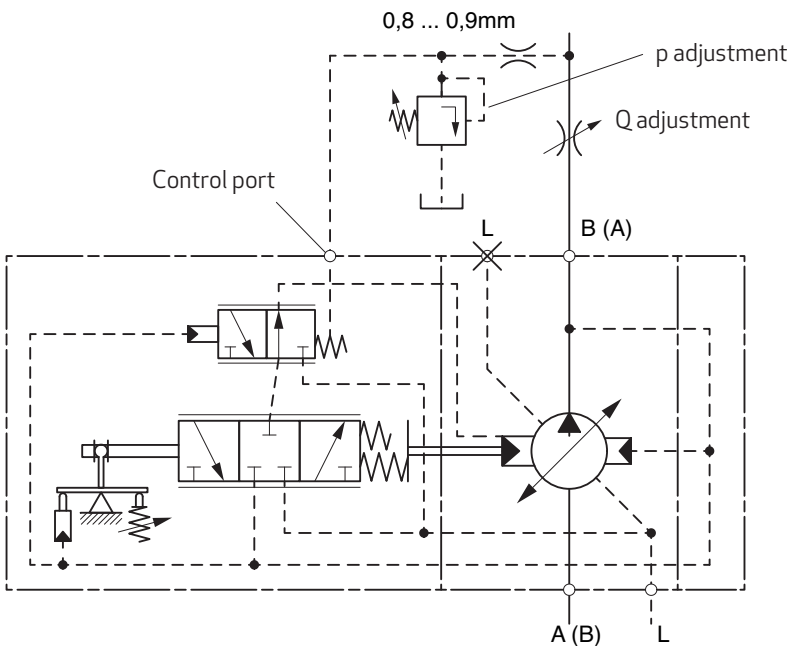
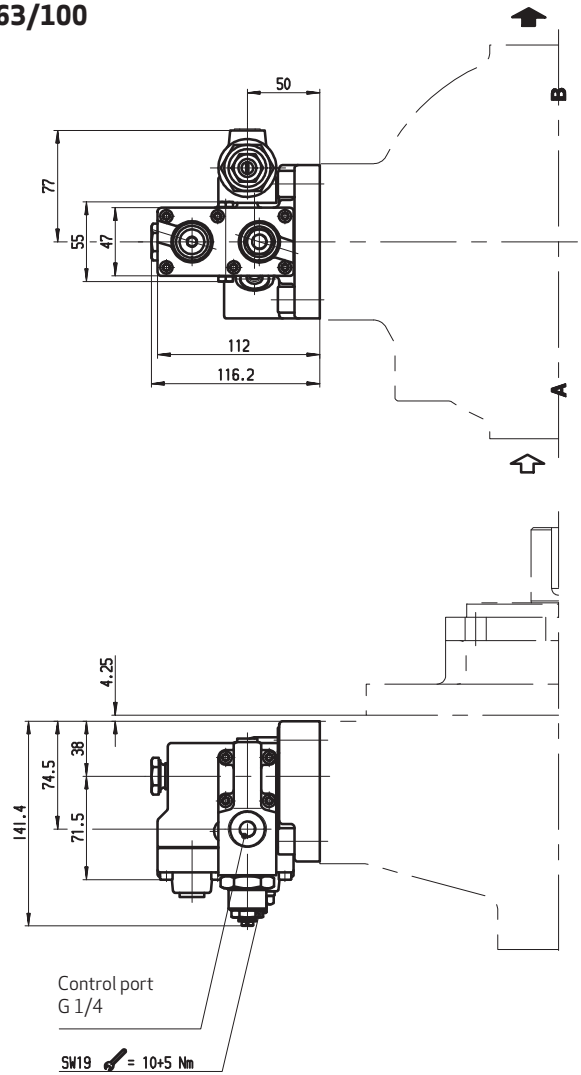

# RADIAL PISTON PUMPS RKP-II

## APPENDIX B – TECHNICAL DRAWINGS COMPENSATORS RKP-II 19 - 100

### SERVO CONTROL C1

#### RKP 19/32/45

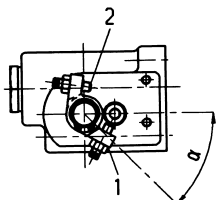
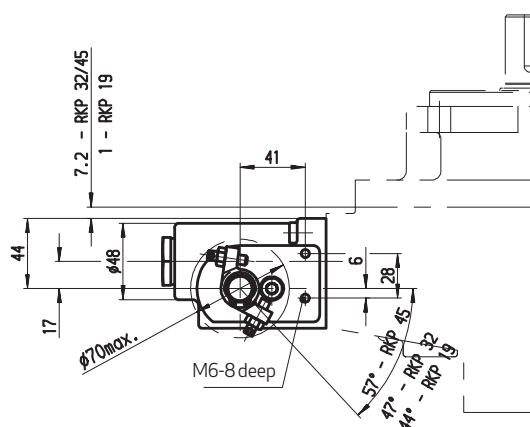
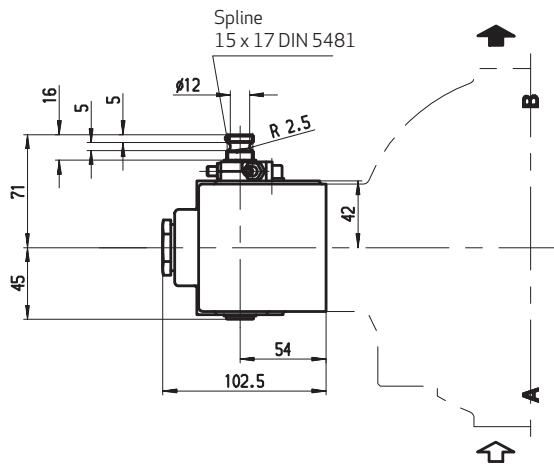

- 1 Zero stroke stop (set at factory)
- 2 End stop /  $\pm V_{max}$ . (set at factory)

#### RKP 63/80/100

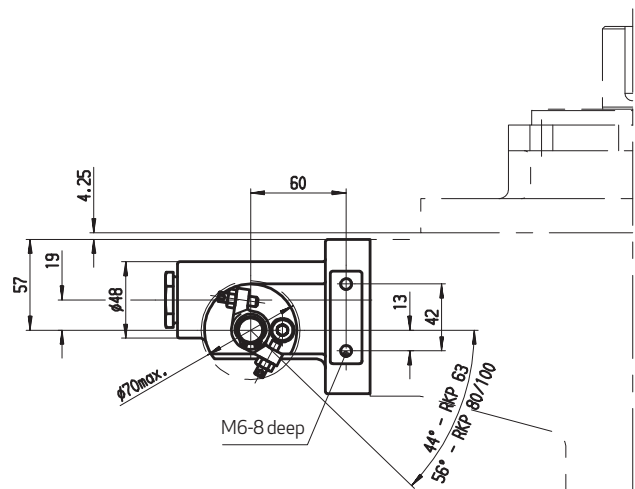
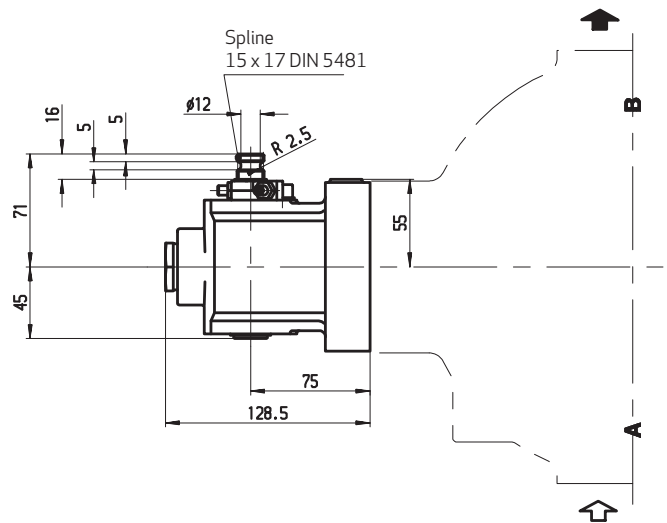

	V [cm <sup>3</sup> /rev]	19	32	45	63	80	100
	$\alpha$ [°]	44	47	57	44	56	56
Torque M [Nm]	Zero position	1.2			1.6		
	End position	1.6	1.7		2.4	2.6	2.6
	max.	8					

# RADIAL PISTON PUMPS RKP-II

## APPENDIX B – TECHNICAL DRAWINGS COMPENSATORS RKP-II 19 - 100

### MAXIMUM FLOW LIMITER Y

#### RKP 19/32/45

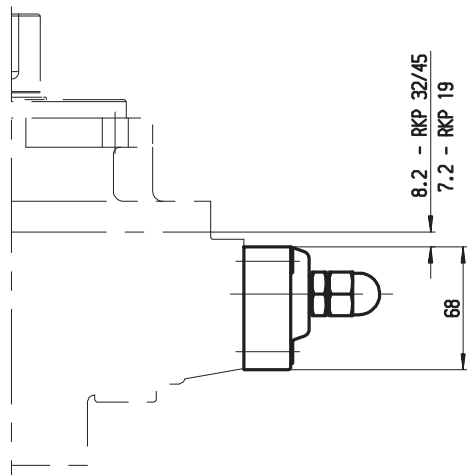
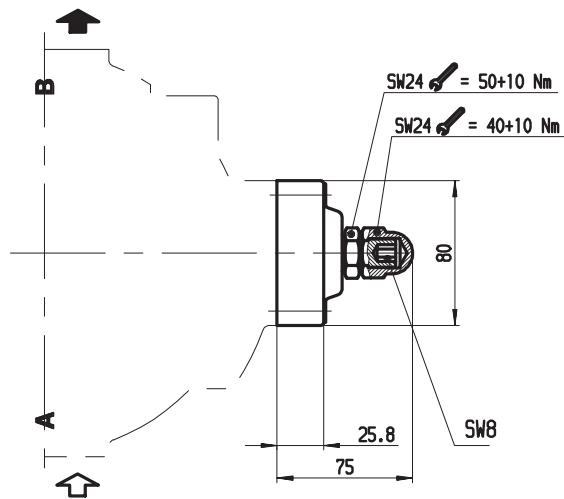

#### RKP 63/80/100

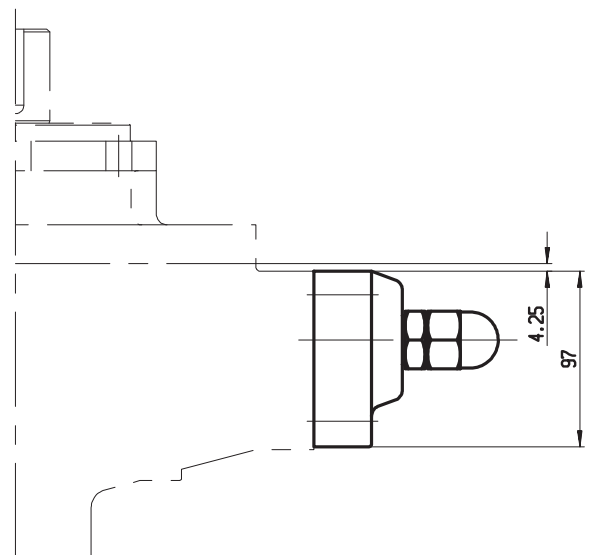
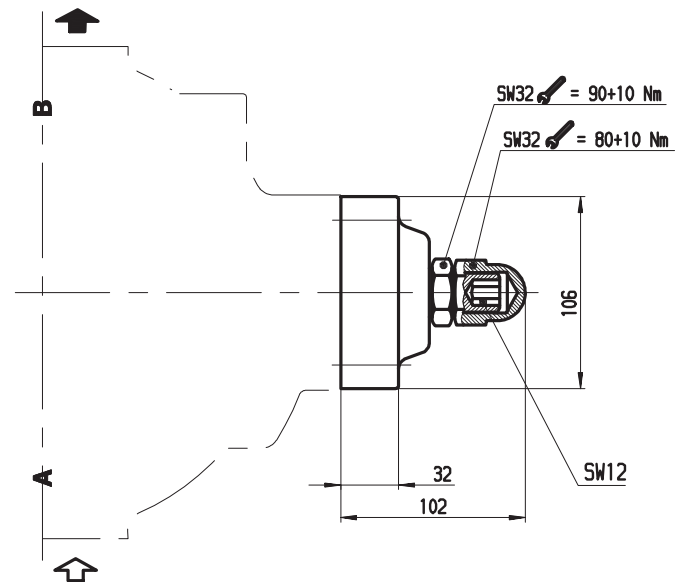

V [cm <sup>3</sup> /rev]	19	32	45	63/80	100
ΔV for 1 mm travel of adjusting screw (pitch 1.5 mm/rev)	3.6	5.6	6.5	8.9	11.3

# RADIAL PISTON PUMPS RKP-II

## APPENDIX B – TECHNICAL DRAWINGS COMPENSATORS RKP-II 19 - 100

### MECHANICAL STROKE ADJUSTMENT (V = CONST.) B1

#### RKP 19/63/80/100

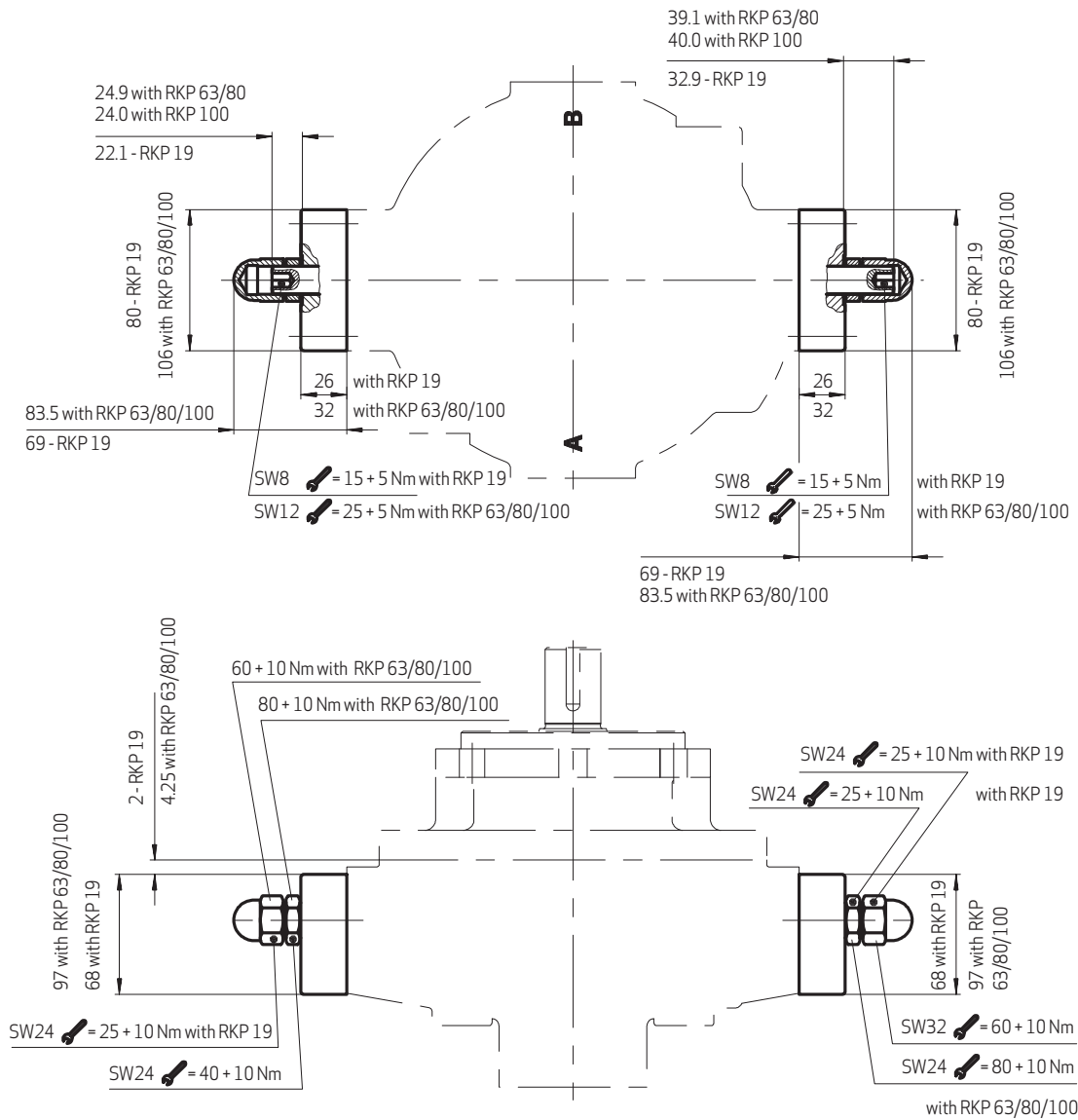

V [cm <sup>3</sup> /rev]	19	63/80	100
ΔV for 1 mm travel of adjusting screw (pitch 1.5 mm/rev)	3.6	8.9	11.3



# RADIAL PISTON PUMPS RKP-II

## APPENDIX B – TECHNICAL DRAWINGS COMPENSATORS RKP-II 19 - 100

### MECHANICAL STROKE ADJUSTMENT (V = CONST.) B1

#### RKP 32/45

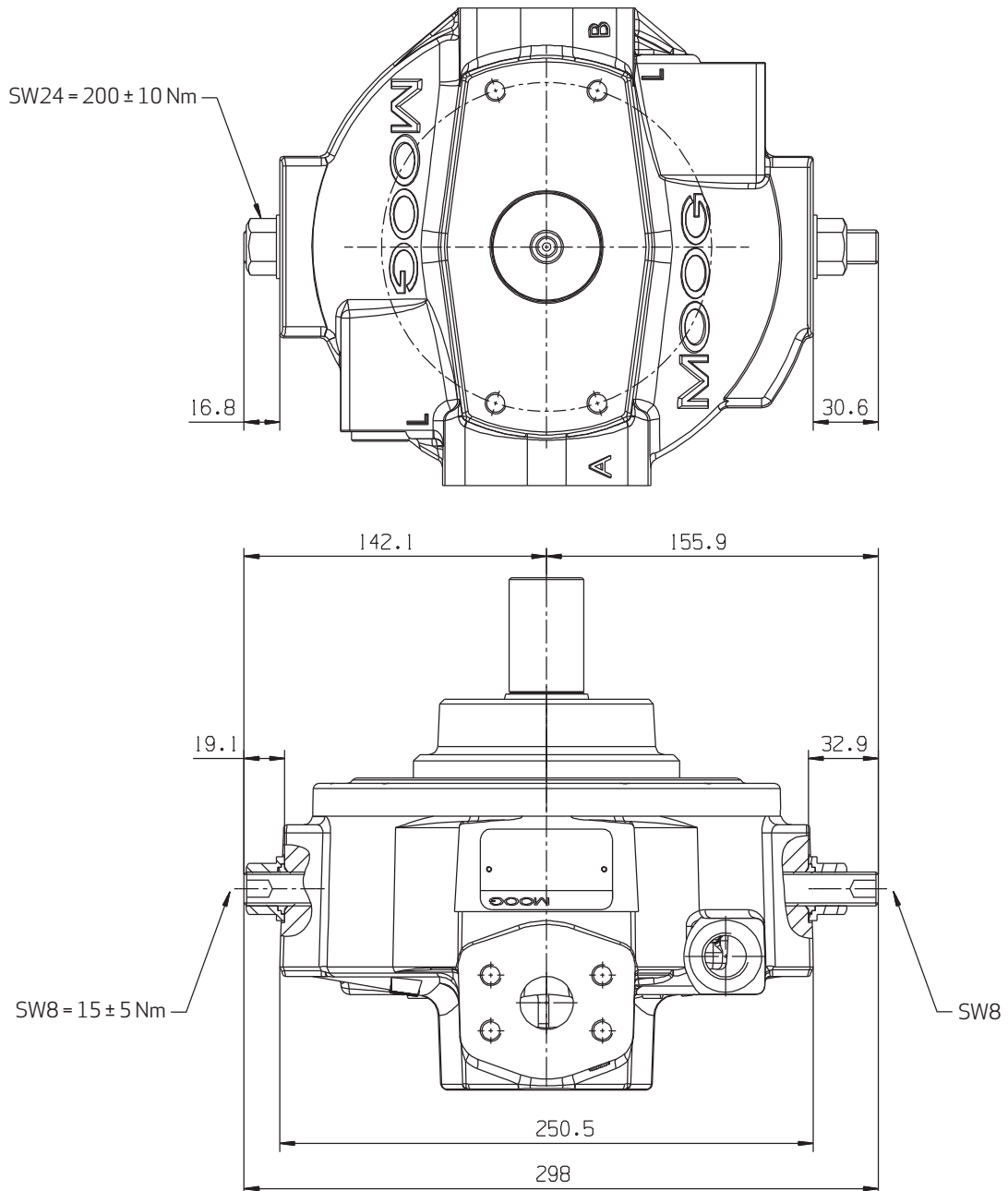

<b>V [cm<sup>3</sup>/rev]</b>	32	45
<b>ΔV for 1 mm travel of adjusting screw (pitch 1.5 mm/rev)</b>	5.6	6.5

#### Important

When adjusting for the required delivery, ensure that the stroke ring remains held between the two adjusting screws. When delivered, the pump is set to  $V_{max}$ .

# RADIAL PISTON PUMPS RKP-II

## APPENDIX B – TECHNICAL DRAWINGS HOUSING RKP-II 140

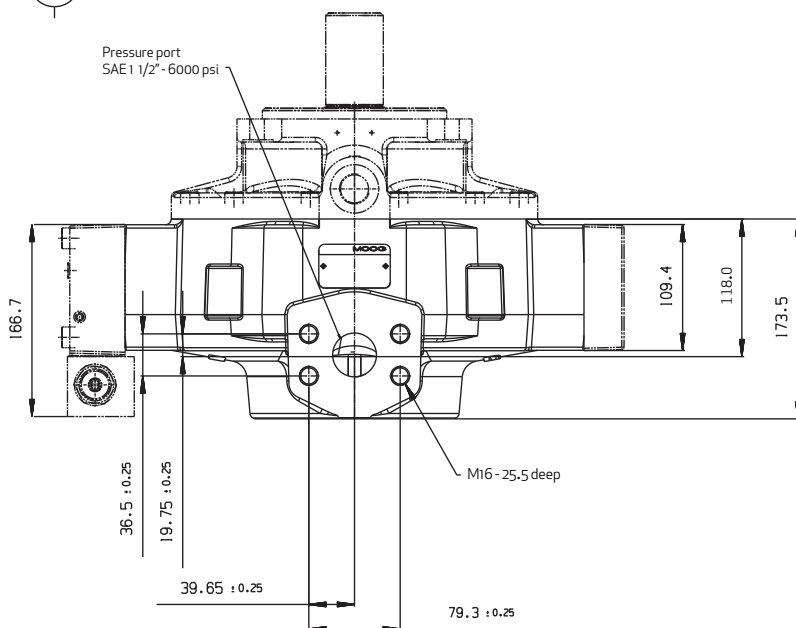
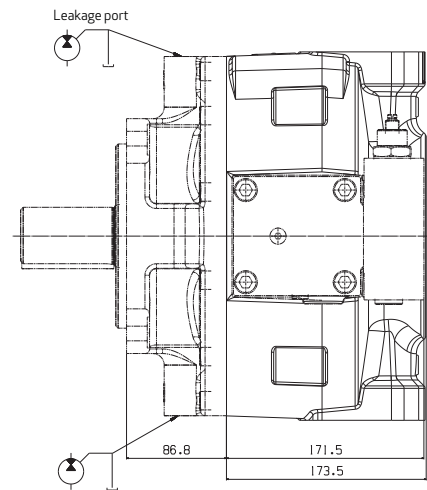
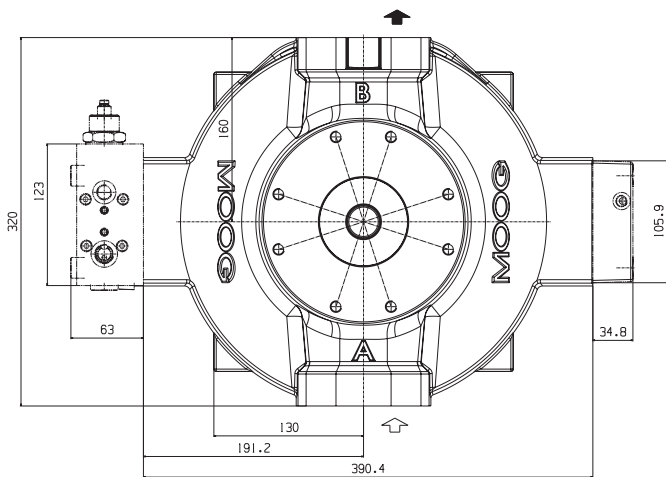
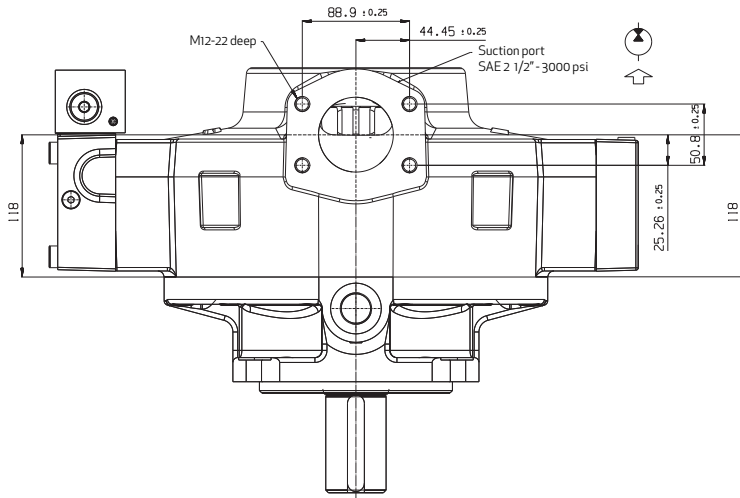

# RADIAL PISTON PUMPS RKP-II

## APPENDIX B – TECHNICAL DRAWINGS FLANGES RKP-II 140

### DRIVE FLANGES A7

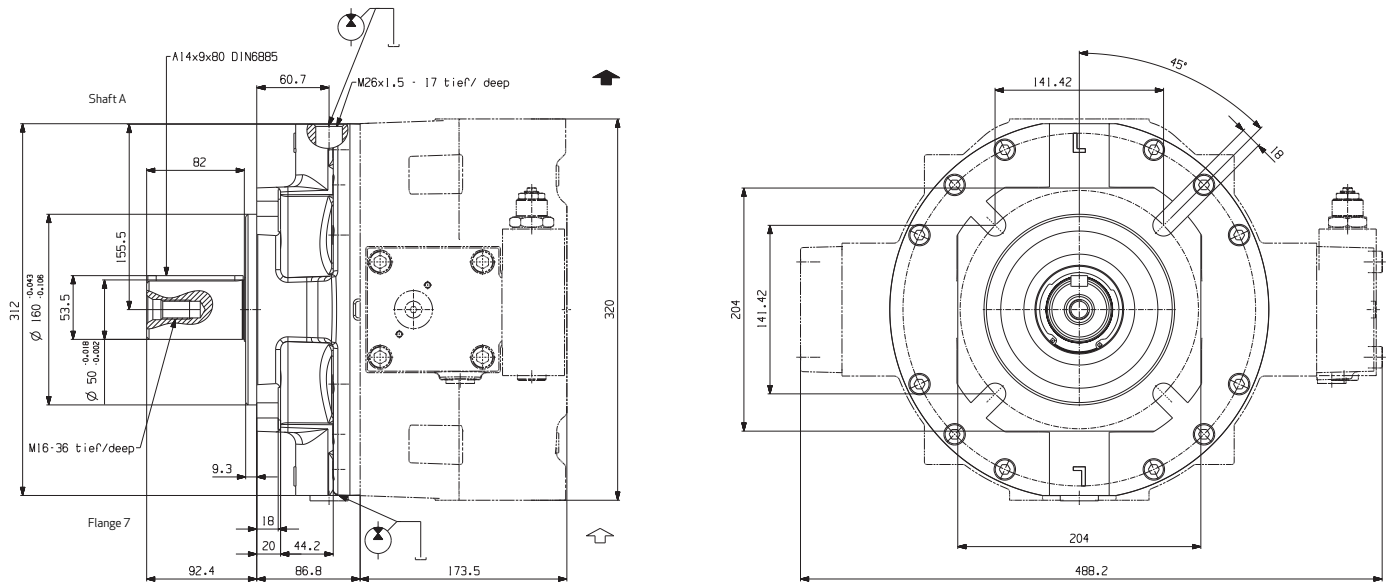

Key to DIN 6885  
ISO mounting flange to DIN ISO 3019/2 (metric dimensions)

### DRIVE FLANGES B7

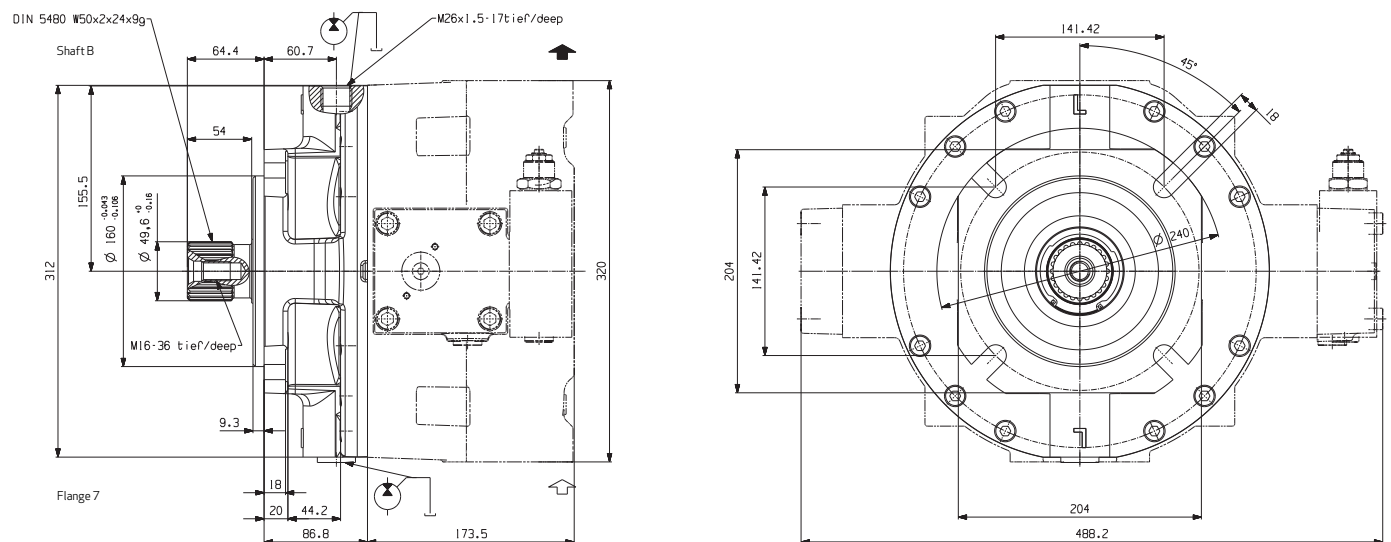

Involute spline to DIN 5480 (for RKP- and SAE-B-mounting obligatory)  
ISO mounting flange to DIN ISO 3019/2 (metric dimensions)

# RADIAL PISTON PUMPS RKP-II

## APPENDIX B – TECHNICAL DRAWINGS DRIVE FLANGES RKP 140

### DRIVE FLANGE C3

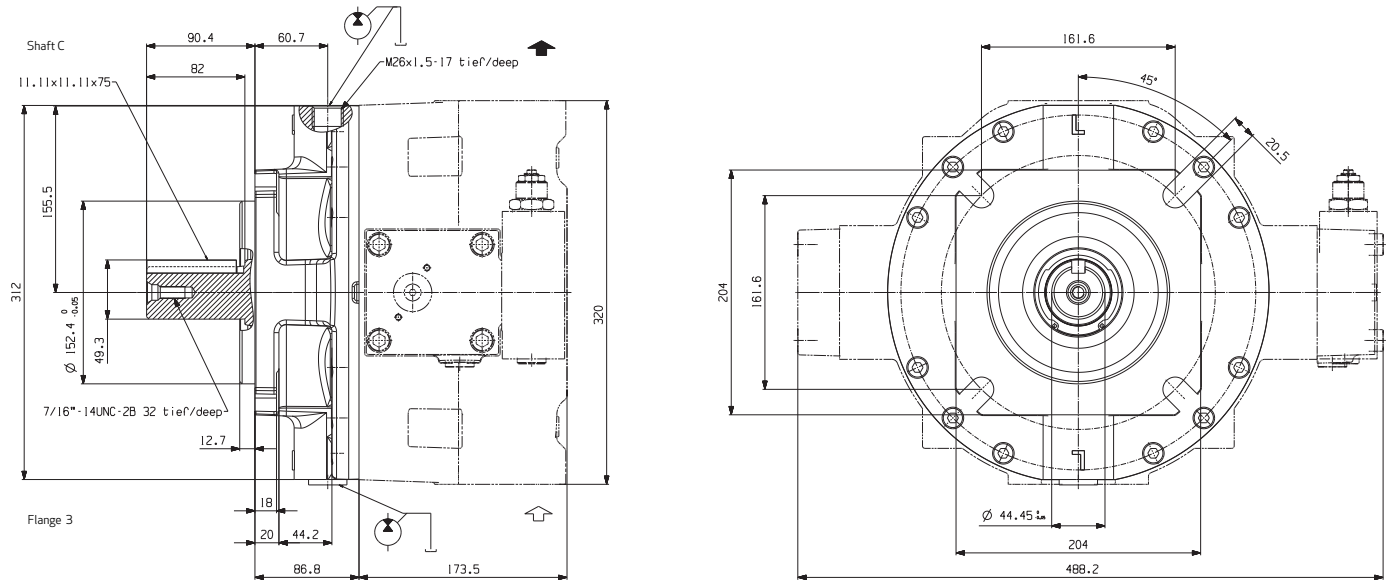

Key to SAE Standard  
SAE mounting flange to DIN ISO 3019/1 (imperial dimensions)

### DRIVE FLANGE D3

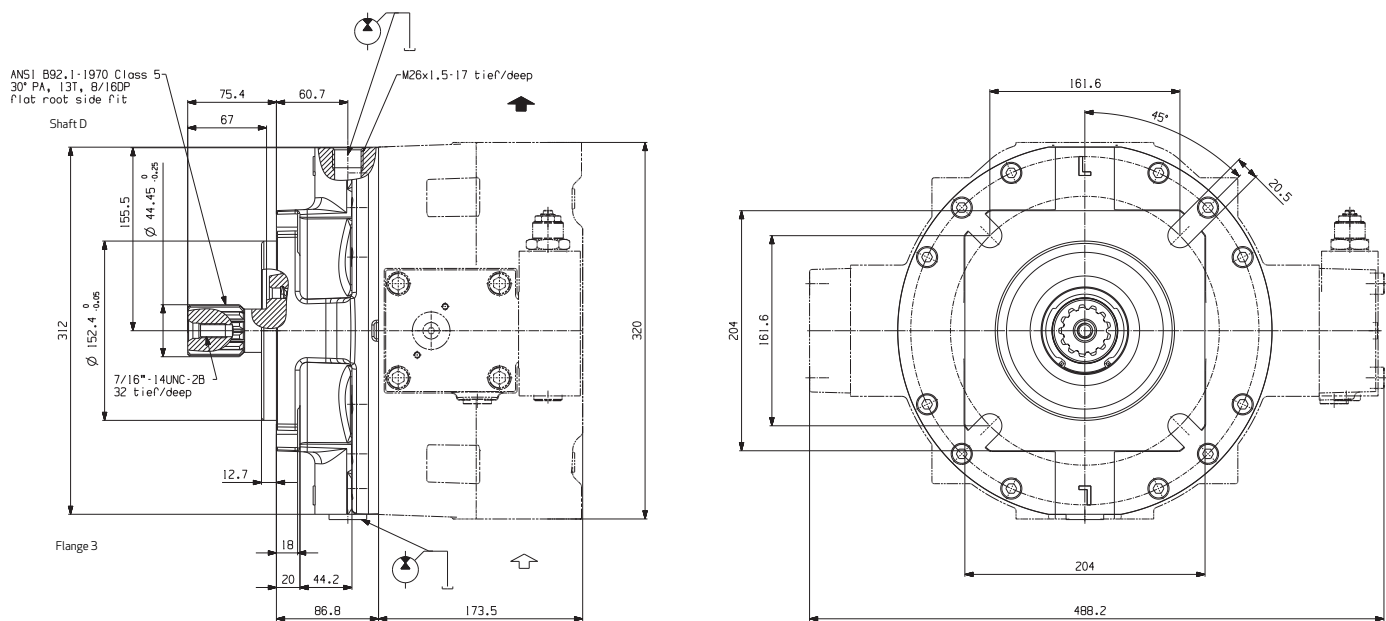

Involute spline to SAE 744 C (for RKP- and SAE-B-mounting obligatory)  
SAE mounting flange to ISO 3019/1 (imperial dimensions)

# RADIAL PISTON PUMPS RKP-II

## APPENDIX B – TECHNICAL DRAWINGS DRIVE FLANGES RKP 140

### INTERMEDIATE FLANGE RKP 140-140

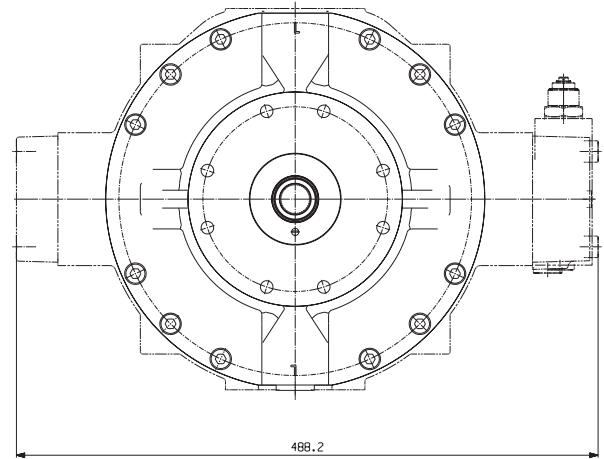
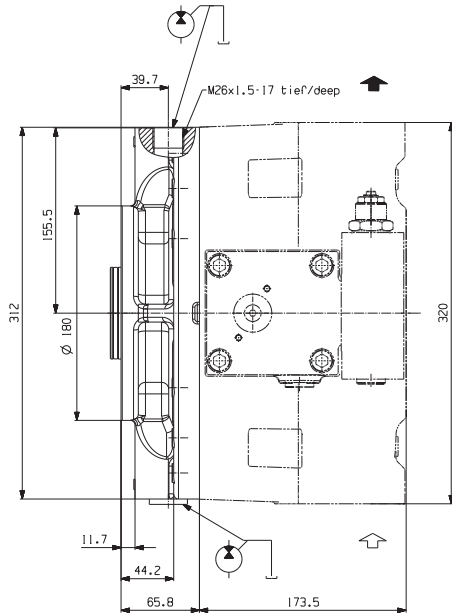

# RADIAL PISTON PUMPS RKP-II

## APPENDIX B – TECHNICAL DRAWINGS COMPENSATORS RKP-II 140

### COMBINED PRESSURE AND FLOW COMPENSATOR "LOAD SENSING" WITH P-T CONTROL NOTCH R1

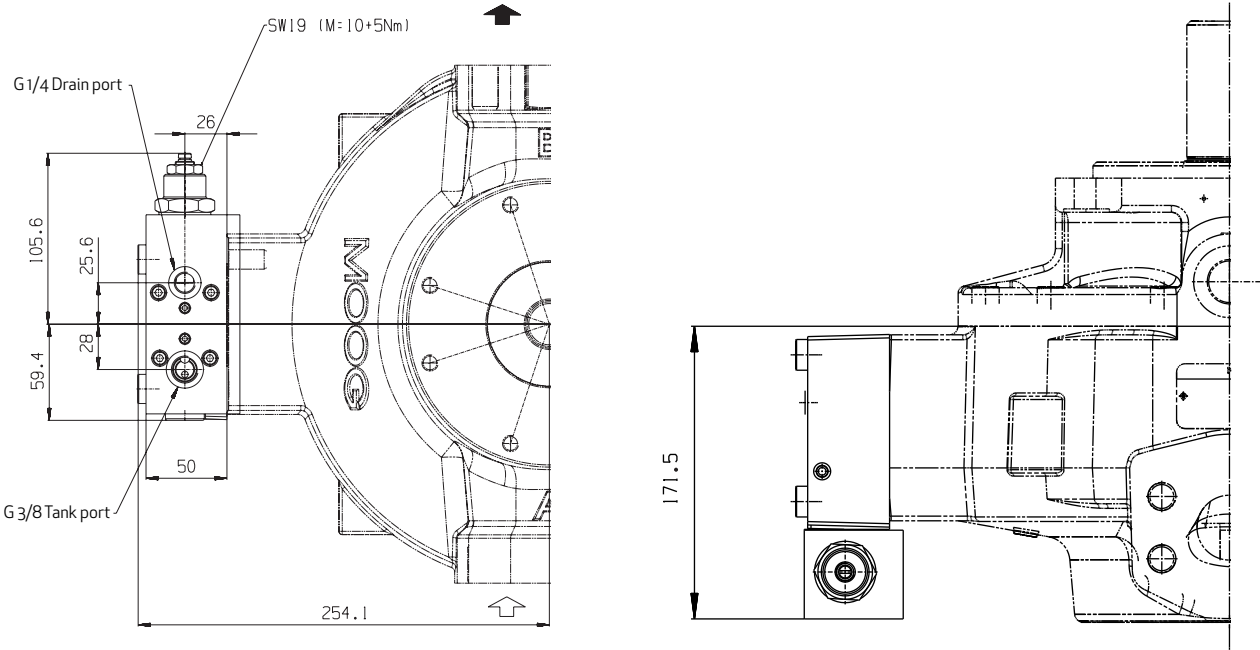

**Caution!**

The tank line of the compensator must not be combined with the drain line of the pump.

Following circuits are illustrated

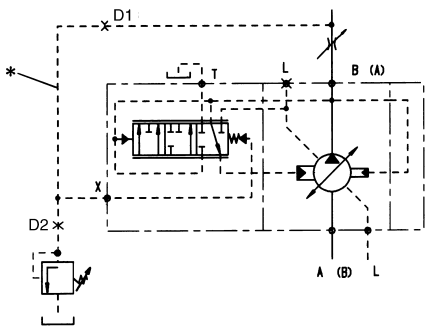

Load sensing

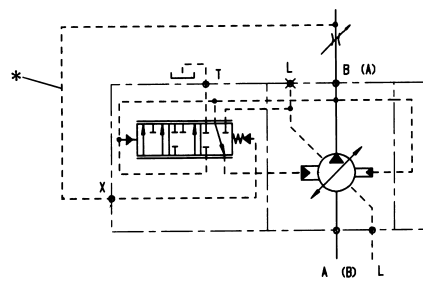

Flow control

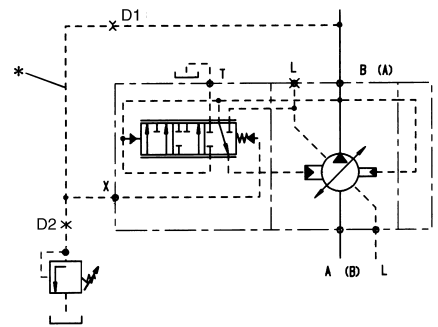

Pressure control

\* Hose recommendation for control line

		D1	D2
RKP 140	DN 8	0.8	1.1
l ≈ 800 mm			

**NOTES ON MULTIPLE PUMP CIRCUITS**

In the case of multiple pumps, which deliver into one circuit, the P-T control notch may only be activated for the compensator of the first pump by connecting the T-connection to the tank. The T-connection of the compensators of add-on pumps must be plugged.

# RADIAL PISTON PUMPS RKP-II

## APPENDIX B – TECHNICAL DRAWINGS COMPENSATORS RKP-II 140

### ELECTRO-HYDRAULIC CONTROL WITH DIGITAL ON-BOARD ELECTRONICS D

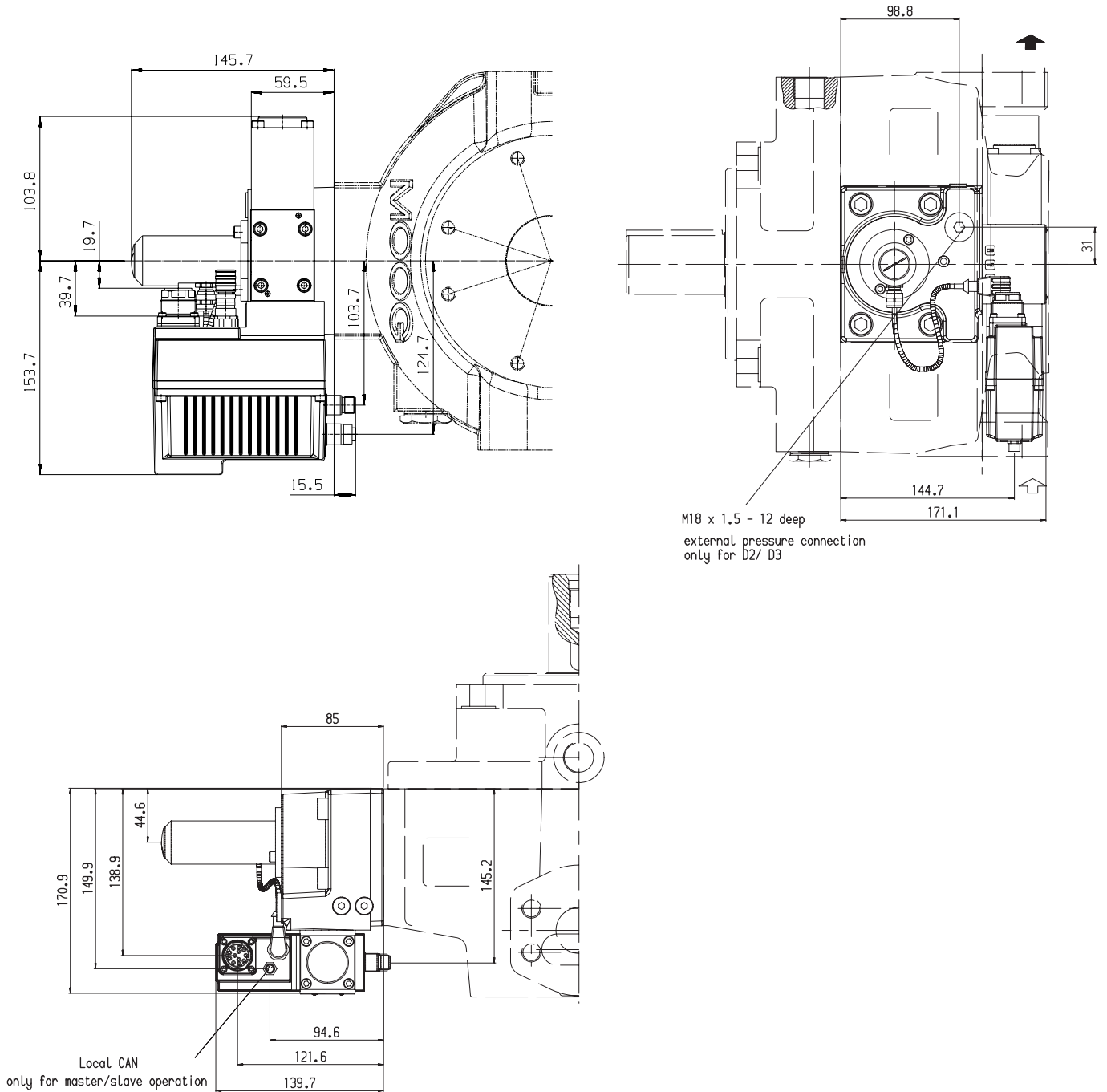

# RADIAL PISTON PUMPS RKP-II

## APPENDIX B – TECHNICAL DRAWINGS COMPENSATORS RKP-II 140

### MAXIMUM FLOW LIMITER Y

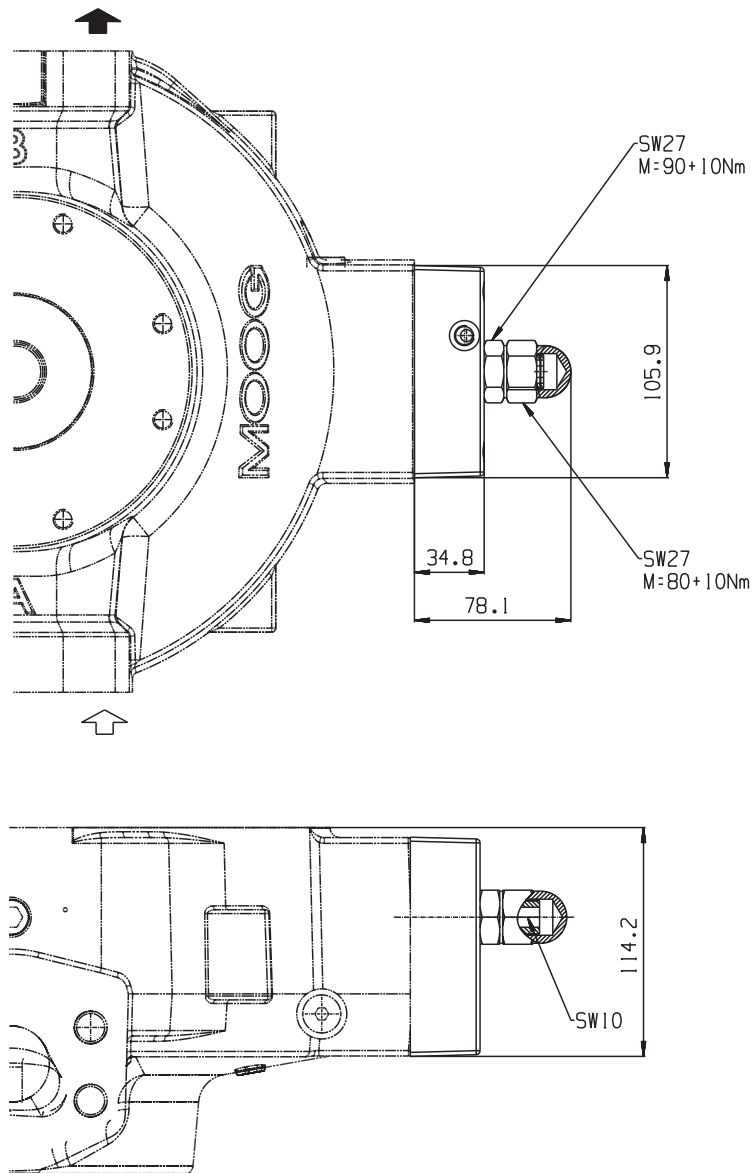

V [cm <sup>3</sup> /rev]	140
ΔV for 1 mm travel of adjusting screw (pitch 1.5 mm/rev)	11.5



# RADIAL PISTON PUMPS RKP-II

## APPENDIX B – TECHNICAL DRAWINGS COMPENSATORS RKP-II 140

### MECHANICAL STROKE ADJUSTMENT B

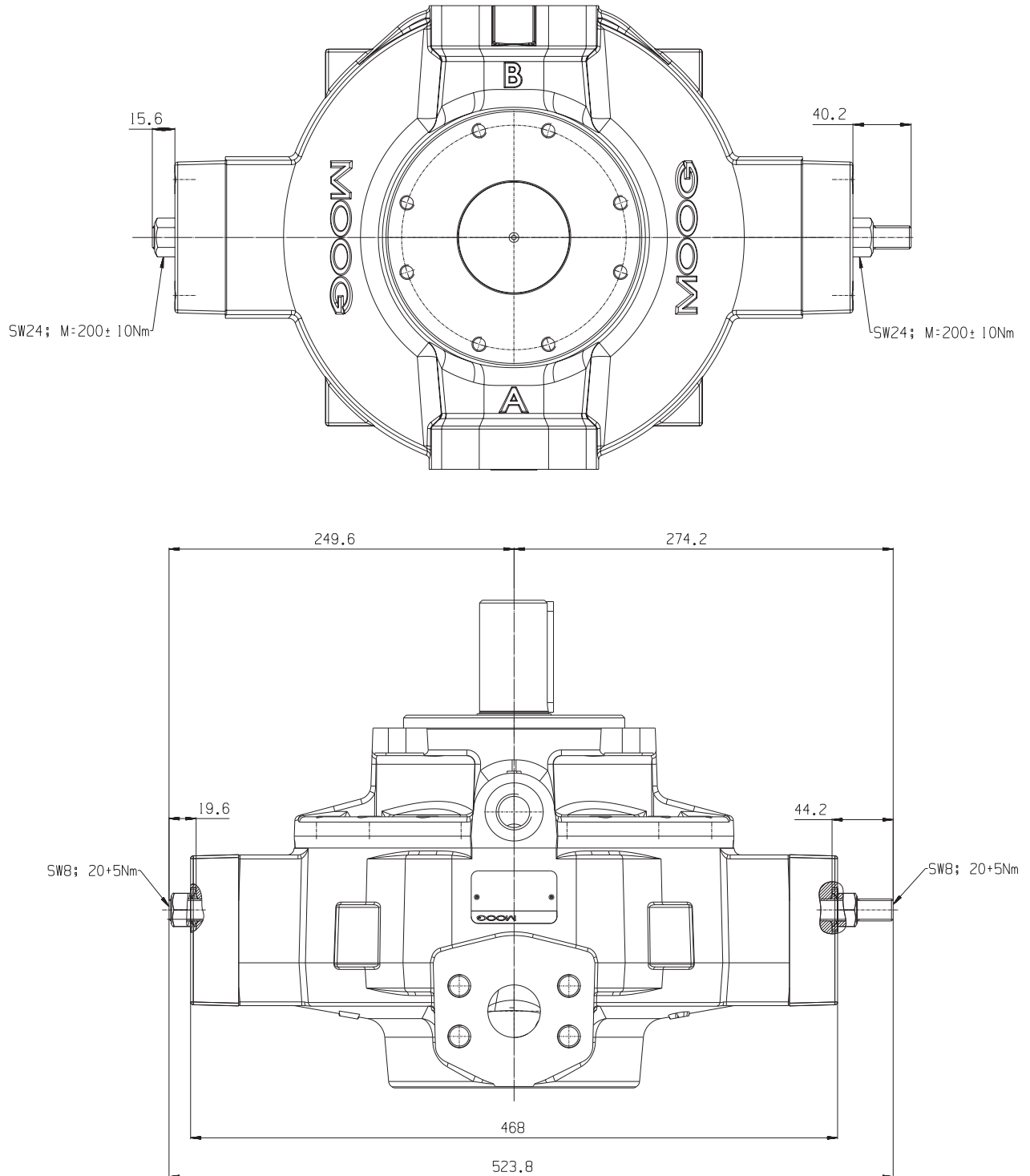

<b>V [cm<sup>3</sup>/rev]</b>	140
<b>ΔV for 1 mm travel of adjusting screw (pitch 1.5 mm/rev)</b>	11.5

# RADIAL PISTON PUMPS RKP-II

## CONVERSION TABLE

### GENERAL CONVERSION TABLE

1 bar	=	14.5038 lb/in <sup>2</sup> (PSI)
1 PSI	=	0.0689 bar
1 mm	=	0.0394 in
1 in	=	25.4 mm
1 cm <sup>3</sup>	=	0.0610 in <sup>3</sup> = 0.000264 gal (US)
1 in <sup>3</sup>	=	16.3871 cm <sup>3</sup> = 0.004329 gal (US)
1 Liter	=	0.26417 gal (US) = 61.024 in <sup>3</sup>
1 gal (US)	=	3.7854 Liter [l] = 231 in <sup>3</sup>
1 kg	=	2.2046 lb
1 lb	=	0.4536 kg
1 Nm	=	8.8507 lbf.in
1 lbf.in	=	0.1130 Nm
1 kW	=	1.3596 PS = 1.3410 hp (UK)
1 hp (UK)	=	1.0139 PS = 0.7457 kW

1 °F	=	0.5556 °C
1 °C	=	1.8 °F
		(°F-32) x 0.5556 = °C
		(°C/0.5556) + 32 = °F
0 °F	=	-17.778 °C
0 °C	=	32 °F
100 °F	=	37.778 °C
100 °C	=	212 °F

### MASS MOMENT OF INERTIA

1 kg.cm <sup>2</sup>	=	0.3417 lb.in <sup>2</sup>
1 lb.in <sup>2</sup>	=	2.9264 kg.cm <sup>2</sup>

### KINEMATIC VISCOSITY

1 mm <sup>2</sup> /s	=	1 cSt = 0.00155 in <sup>2</sup> /s
1 in <sup>2</sup> /s	=	645.16 cSt = 645.16 mm <sup>2</sup> /s

### CALCULATION OF POWER CONSUMPTION OF A PUMP

$$P = \frac{p \times Q}{6 \times \eta}$$

P [kW]

p [bar]

Q [l/min]

η [%]

**Example: RKP 63 cm<sup>3</sup>/rev, 280 bar, 1450 rpm:**

p = 280 bar

Q = (63 x 1,450) = 91.3 l/min

η = 95 %

P = 280 x 91.3 / (6 x 95)

P = 45 kW

### CALCULATION OF DRIVE TORQUE

$$M = \frac{1.59 \times V \times p}{\eta}$$

M [Nm]

V [cm<sup>3</sup>/rev]

p [bar]

η [%]

**Example: RKP 63cm<sup>3</sup>/rev, 280 bar:**

V = 63 cm<sup>3</sup>/rev,

p = 280 bar,

η = 95 %

M = 1.59 x 63 x 280 / 95

M = 295 Nm

**All dimensions in the catalog are in mm unless otherwise specified.**

# RADIAL PISTON PUMPS RKP-II

## GLOBAL SUPPORT AND FURTHER INFORMATION

---

### GLOBAL SUPPORT

As a recognized leader in motion control technologies, Moog offers a full range of services to support our products and ensure that they meet the expectations of customers.

Moog experts are the best at helping customers select the right products and ensuring that they run reliably for a long time. When it is time for new machine commissioning, refurbishment or routine maintenance, our engineers can help to optimize machine performance, minimize downtime and ensure the smooth application of our products.

Known for the ability to customize products for the specific needs of our customers, we are uniquely able to handle customer needs and supply services throughout the life cycle of the product. **Moog Authentic Repair®** is designed to provide the highest quality repair services using original equipment parts, the latest design specifications, and highly trained technicians. This ensures that our repaired products will run as well as when they were new.

With facilities in over 25 countries, Moog is committed to offering convenient local service to our customers.

Visit [www.moog.com/industrial/globallocator](http://www.moog.com/industrial/globallocator) to find the location nearest you for application engineering, repair, or field services.

### FOR MORE INFORMATION VISIT

<http://www.moog.com/industrial>

# MOOG.COM/INDUSTRIAL

For the Moog location nearest you,  
visit [moog.com/industrial/globallocator](http://moog.com/industrial/globallocator).

Argentina	+54	(0) 11 4326 5916	<a href="mailto:info.argentina@moog.com">info.argentina@moog.com</a>
Australia	+61	(0) 3 9561 6044	<a href="mailto:info.australia@moog.com">info.australia@moog.com</a>
Austria	+43	(0) 1 688 1384	<a href="mailto:info.austria@moog.com">info.austria@moog.com</a>
Brazil	+55	(0) 11 3572 0400	<a href="mailto:info.brazil@moog.com">info.brazil@moog.com</a>
China	+86	(0) 21 2893 1600	<a href="mailto:info.china@moog.com">info.china@moog.com</a>
Finland	+358	(0) 9 2517 2730	<a href="mailto:info.finland@moog.com">info.finland@moog.com</a>
France	+33	(0) 1 4560 7000	<a href="mailto:info.france@moog.com">info.france@moog.com</a>
Germany	+49	(0) 7031 622 0	<a href="mailto:info.germany@moog.com">info.germany@moog.com</a>
Hong Kong	+852	2 635 3200	<a href="mailto:info.hongkong@moog.com">info.hongkong@moog.com</a>
India	+91	(0) 80 4120 8799	<a href="mailto:info.india@moog.com">info.india@moog.com</a>
Ireland	+353	(0)21 451 9000	<a href="mailto:info.ireland@moog.com">info.ireland@moog.com</a>
Italy	+39	0 332 42111	<a href="mailto:info.italy@moog.com">info.italy@moog.com</a>
Japan	+81	(0) 46 355 3615	<a href="mailto:info.japan@moog.com">info.japan@moog.com</a>
Korea	+82	(0) 31 764 6711	<a href="mailto:info.korea@moog.com">info.korea@moog.com</a>
Luxembourg	+352	40 46 401	<a href="mailto:info.luxembourg@moog.com">info.luxembourg@moog.com</a>
Netherlands	+31	(0) 252 462 000	<a href="mailto:info.netherlands@moog.com">info.netherlands@moog.com</a>
Norway	+47	224 32927	<a href="mailto:info.norway@moog.com">info.norway@moog.com</a>
Russia	+7	(8) 31 713 1811	<a href="mailto:info.russia@moog.com">info.russia@moog.com</a>
Singapore	+65	677 36238	<a href="mailto:info.singapore@moog.com">info.singapore@moog.com</a>
South Africa	+27	(0) 12 653 6768	<a href="mailto:info.southafrica@moog.com">info.southafrica@moog.com</a>
Spain	+34	902 133 240	<a href="mailto:info.spain@moog.com">info.spain@moog.com</a>
Sweden	+46	(0) 31 680 060	<a href="mailto:info.sweden@moog.com">info.sweden@moog.com</a>
Switzerland	+41	(0) 71 394 5010	<a href="mailto:info.switzerland@moog.com">info.switzerland@moog.com</a>
United Kingdom	+44	(0) 168 429 6600	<a href="mailto:info.unitedkingdom@moog.com">info.unitedkingdom@moog.com</a>
USA	+1	(1) 716 652 2000	<a href="mailto:info.usa@moog.com">info.usa@moog.com</a>

©2007 Moog Inc.

Moog is a registered trademark of Moog, Inc. and its subsidiaries.  
All trademarks as indicated herein are the property of Moog, Inc.  
and its subsidiaries. All rights reserved.

RKP-II\_de\_3/2007